



**Systèmes pour Douches**  
*Shower systems*

**ASSA ABLOY**

Systèmes  
coulissants  
pour douches  
*Sliding shower  
system*

# Eloa

## Caractéristiques techniques

- Pour verre trempé de 8 mm (non fourni)
- Poids maxi par porte : 30 kg
- Entre deux murs : largeur maxi 2200 mm

• **Le sens d'ouverture de la porte (droite ou gauche) doit être déterminé avant la réalisation des volumes**

## Technical features

- For toughened glass doors 8 mm (not supplied)
  - Maximum door weight : 30 kg
  - Between two walls : maximum width 2200 mm
- **The opening direction (right or left) must be determined before glass manufacture**

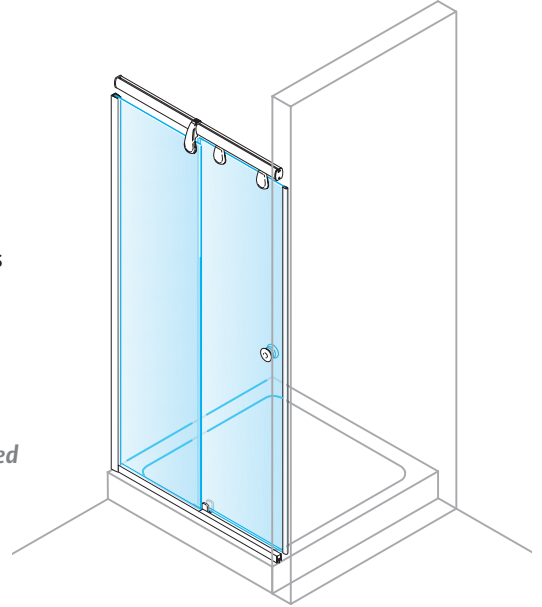

## LES + PRODUITS

The + product

Design épuré  
Entretien facile  
Gain de place

*Refined design  
Easy cleaning  
Space saving*

# 2820.\*\*.1

## Références / References



**Kits complets / Complete kits**



Chromé brillant  
Bright chromium



Chromé mat  
Matt chromium

Système mur/mur 1 volume fixe et 1 ouvrant coulissant  
*System wall/wall 1 fixed panel and sliding panel*

**2820.30.1**

**2820.31.1**

Largeur mur/mur <i>Width wall/wall</i>	Largeur de passage <i>Passage width</i>
1100	525
1000	475
900	425
800	375

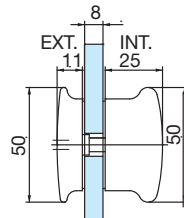
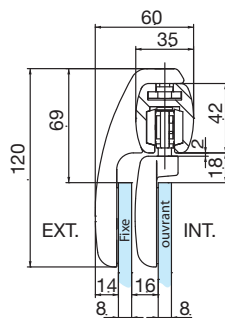
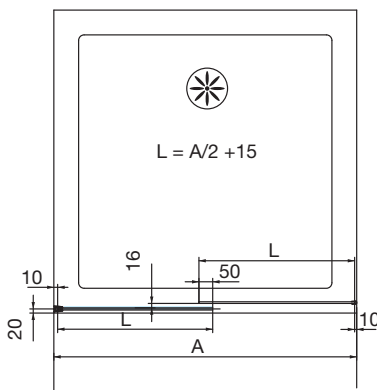

TROUS FRAISES  
*Holes milled*

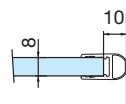
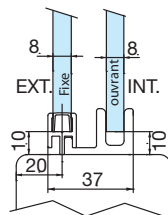
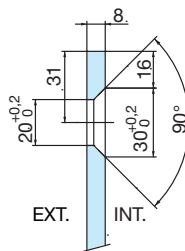

Attention : trous fraisés sur la face intérieure de la douche  
*Caution : holes milled on the inside face of the shower*

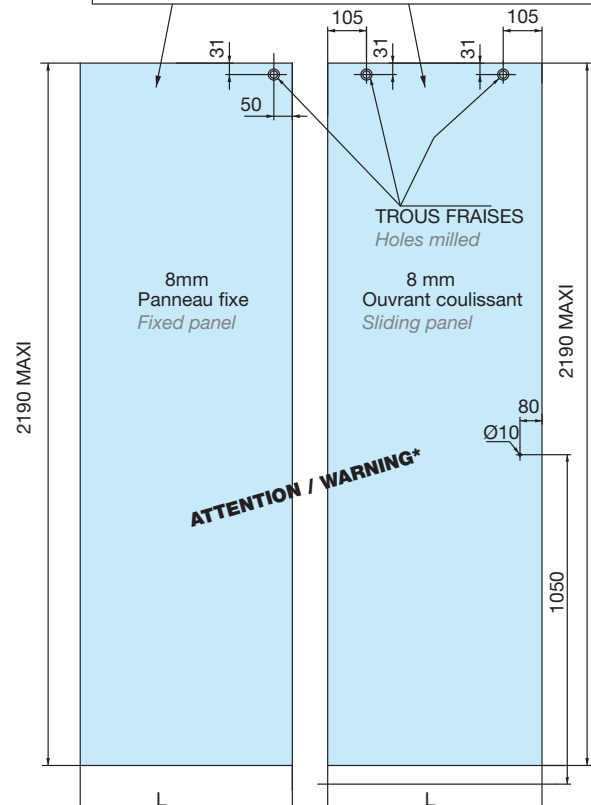

\* Plan valable uniquement pour une porte à droite, pour porte à gauche, inverser le sens des fraisures  
*Drawing is valid only for doors on the right hand side, for the left hand side, reverse the direction of countersinking*

Systèmes  
coulissants  
pour douches  
*Sliding shower  
system*



Systèmes  
couissants  
pour douches  
*Sliding shower  
system*

# Eloa

## Caractéristiques techniques

- Pour verre trempé de 8 mm (non fourni)
- Poids maxi par porte : 30 kg
- Douche d'angle largeur receveur jusqu'à 1100 x 1100 mm

• **Le sens d'ouverture de la porte (droite ou gauche) doit être déterminé avant la réalisation des volumes**

## Technical features

- For toughened glass doors 8 mm (not supplied)
  - Maximum door weight : 30 kg
  - Corner access maximum size of shower tray : 1100 mm x 1100 mm
- **The opening direction (right or left) must be determined before glass manufacture**

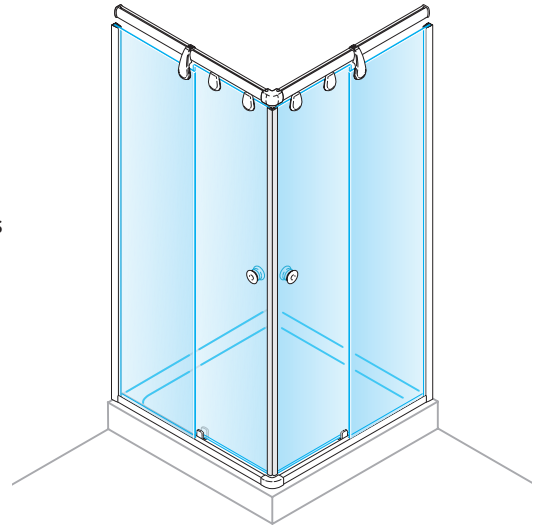

2820.\*\*.2

## Références / References



Kits complets / Complete kits



Chromé brillant  
Bright chromium



Chromé mat  
Matt chromium

Système d'angle 2 volumes fixes et 2 ouvrants couissants  
Corner system 2 fixed panels and 2 sliding panels

2820.30.2

2820.31.2

## LES + PRODUITS

The + product

Grande qualité  
de finitions

Confort d'utilisation

High quality finishes  
Great user comfort

TROUS FRAISES  
Holes milled

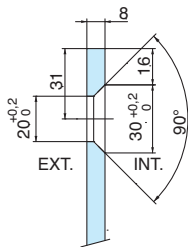

Largeur mur/mur Width wall/wall	Largeur de passage Passage width
1100	710
1000	640
900	570
800	500

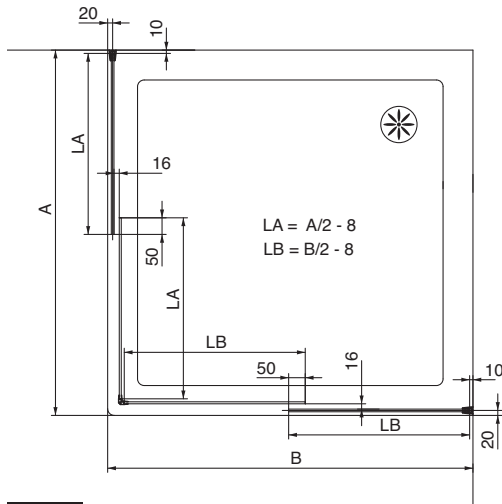

Attention : trous fraisés sur la face intérieure de la douche  
Caution : holes milled on the inside face of the shower

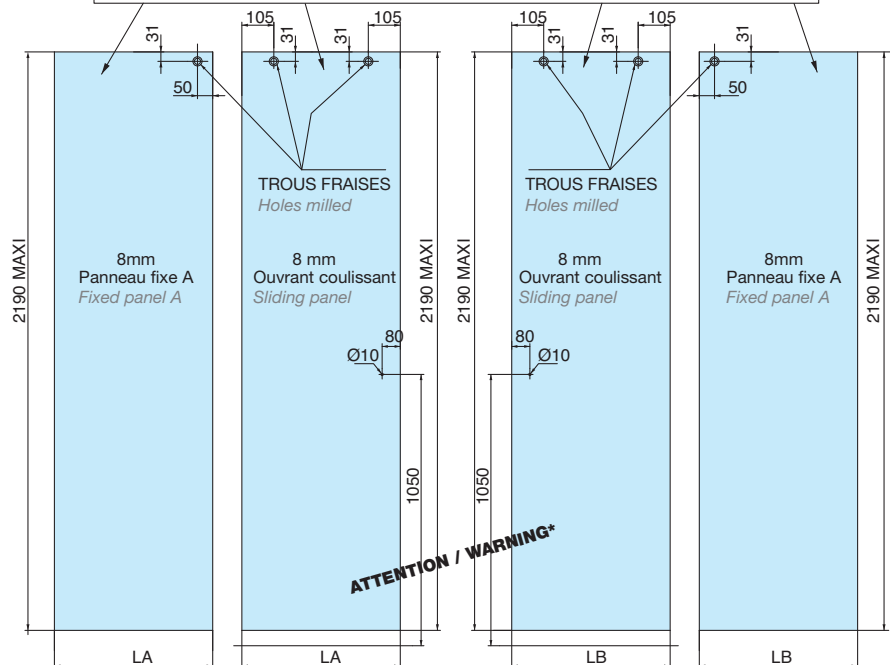

ATTENTION / WARNING\*

\* Plan valable uniquement pour une porte à droite, pour porte à gauche, inverser le sens des fraisesures

Drawing is valid only for doors on the right hand side, for the left hand side, reverse the direction of countersinking

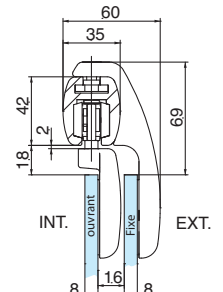
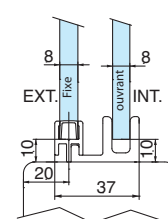
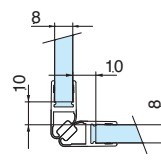
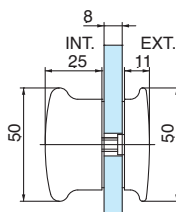



### Caractéristiques techniques

- Pour verre trempé de 8 mm (non fourni)
- Poids maxi par porte : 30 kg
- Douche d'angle largeur receveur jusqu'à 1100 x 1100 mm
- **Le sens d'ouverture de la porte (droite ou gauche) doit être déterminé avant la réalisation des volumes**

### Technical features

- For toughened glass doors 8 mm (not supplied)
- Maximum door weight : 30 kg
- Corner access maximum size of shower tray : 1100 mm x 1100 mm
- **The opening direction (right or left) must be determined before glass manufacture**

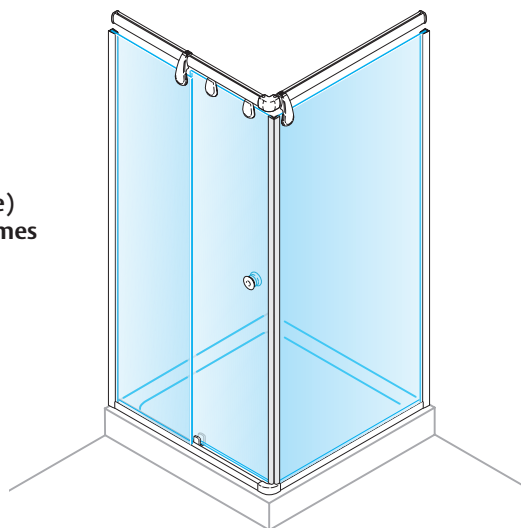

2820.\*\*.3

### Références / References



Kits complets / Complete kits



Chromé brillant  
Bright chromium



Chromé mat  
Matt chromium

Système d'angle 2 volumes fixes et 1 ouvrant coulissant  
Corner system 2 fixed panels and 1 sliding panel

2820.30.3

2820.31.3

Largeur mur/mur Width wall/wall	Largeur de passage Passage width
1100	525
1000	475
900	425
800	375

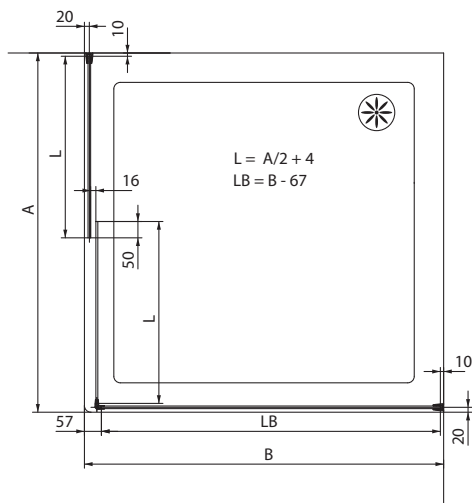

TROUS FRAISES  
Holes milled

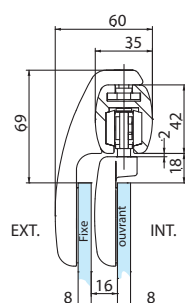
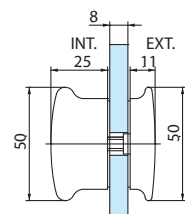
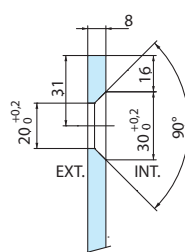

Attention : trous fraisés sur la face intérieure de la douche  
Caution : holes milled on the inside face of the shower

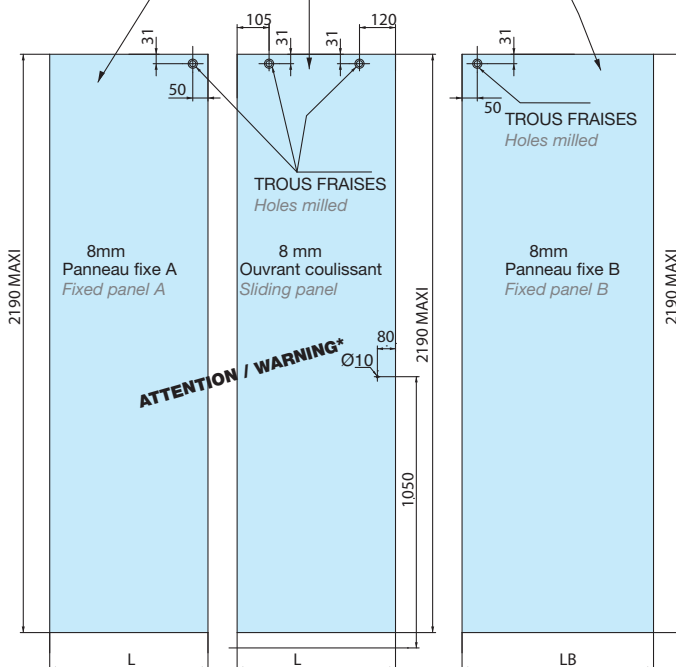

\* Plan valable uniquement pour une porte à droite, pour porte à gauche, inverser le sens des fraises  
Drawing is valid only for doors on the right hand side, for the left hand side, reverse the direction of countersinking

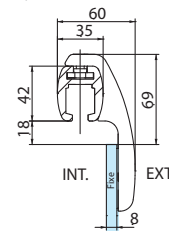
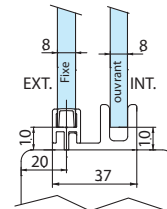
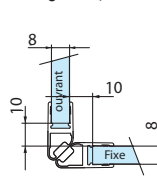



### Caractéristiques techniques

- Pour verre trempé de 8 mm (non fourni)
- Poids maxi par porte : 30 kg
- Entre deux murs : largeur maxi 2200 mm
- Le sens d'ouverture de la porte (droite ou gauche) doit être déterminé avant la réalisation des volumes

### Technical features

- For toughened glass doors 8 mm (not supplied)
- Maximum door weight : 30 kg
- Between two walls : maximum width 2200 mm
- The opening direction (right or left) must be determined before glass manufacture

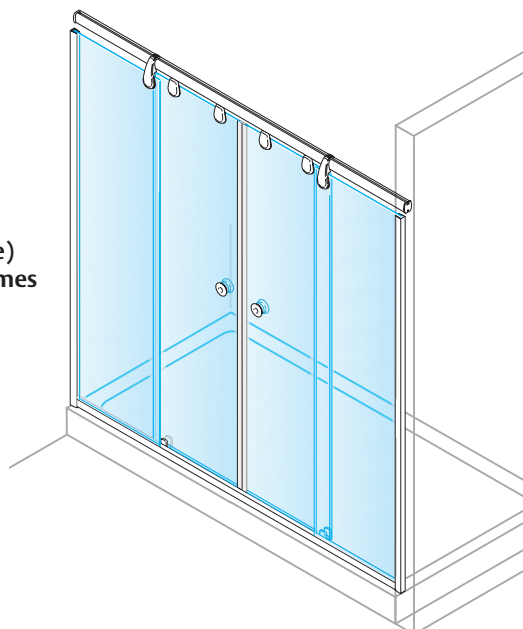

2820.\*\*.5

### Références / References



Kits complets / Complete kits



Chromé brillant  
Bright chromium



Chromé mat  
Matt chromium

Système mur/mur 2 volumes fixes et 2 ouvrants couissants  
System wall/wall 2 fixed panels and 2 sliding panels

2820.30.5

2820.31.5

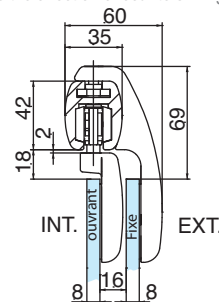
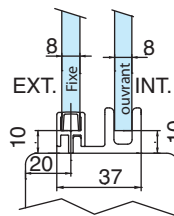
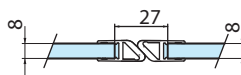
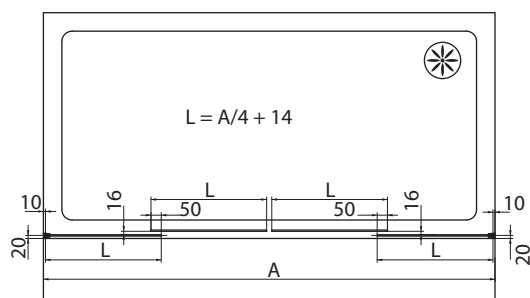
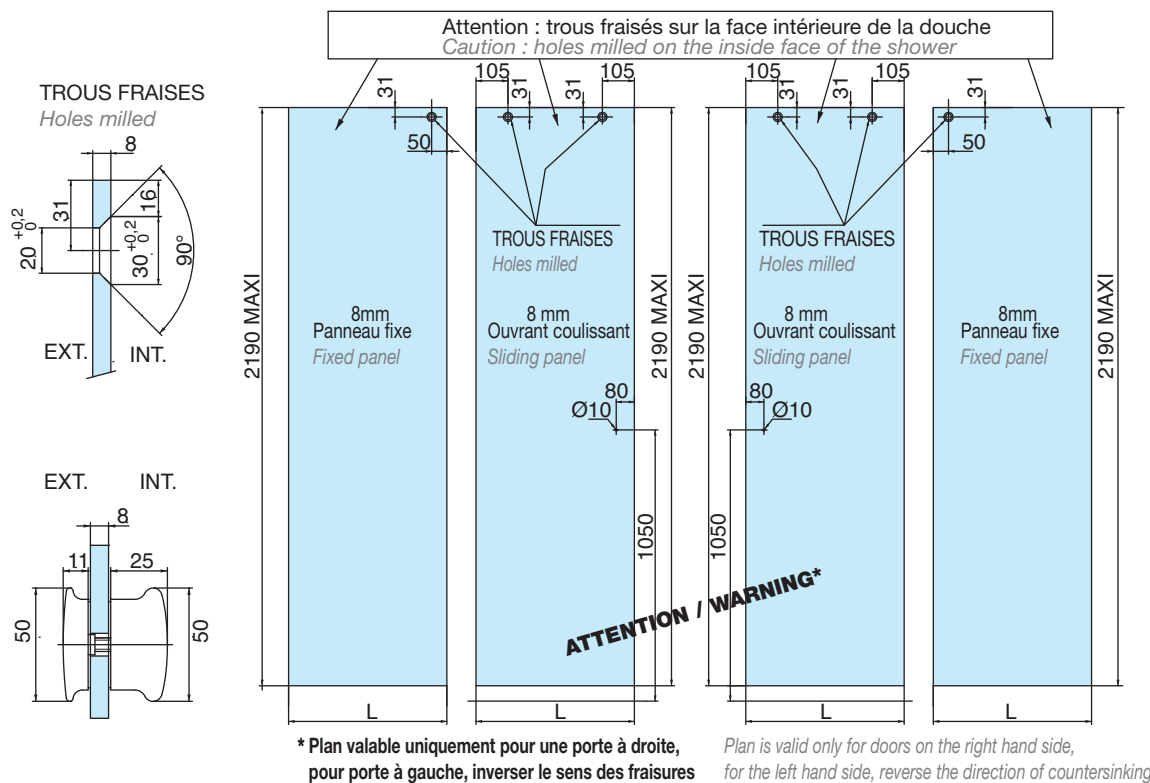







Systèmes  
coulissants  
pour douches  
Sliding shower  
system

# Eloa

## Caractéristiques techniques

- Pour verre trempé de 8 mm (non fourni)
- Poids maxi par porte : 30 kg
- Douche d'angle largeur receveur jusqu'à 1100 x 1100 mm

- Le sens d'ouverture de la porte (droite ou gauche) doit être déterminé avant la réalisation des volumes

## Technical features

- For toughened glass doors 8 mm (not supplied)
- Maximum door weight : 30 kg
- Corner access maximum size of shower tray : 1100 mm x 1100 mm

- The opening direction (right or left) must be determined before glass manufacture

2820.\*\*.9

## Références / References



Kits complets / Complete kits



Chromé brillant  
Bright chromium



Chromé mat  
Matt chromium



Laqué Blanc 9010  
Lacquered white RAL 9010

Système d'angle 1 volume fixe, 1 ouvrant coulissant et 2 volumes repliables  
Corner system 1 fixed panel, 1 sliding panel and 2 folding panels

2820.30.9

2820.31.9

2820.51.9

## LES + PRODUITS

The + product

Accès adapté  
pour personne  
à mobilité réduite

Adapted  
for disabled people

## TROUS FRAISES Holes milled

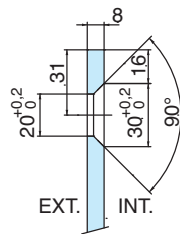

ENCOCHE MV  
Notch MV

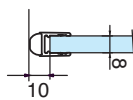
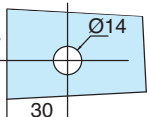

ENCOCHE VV  
Notch VV

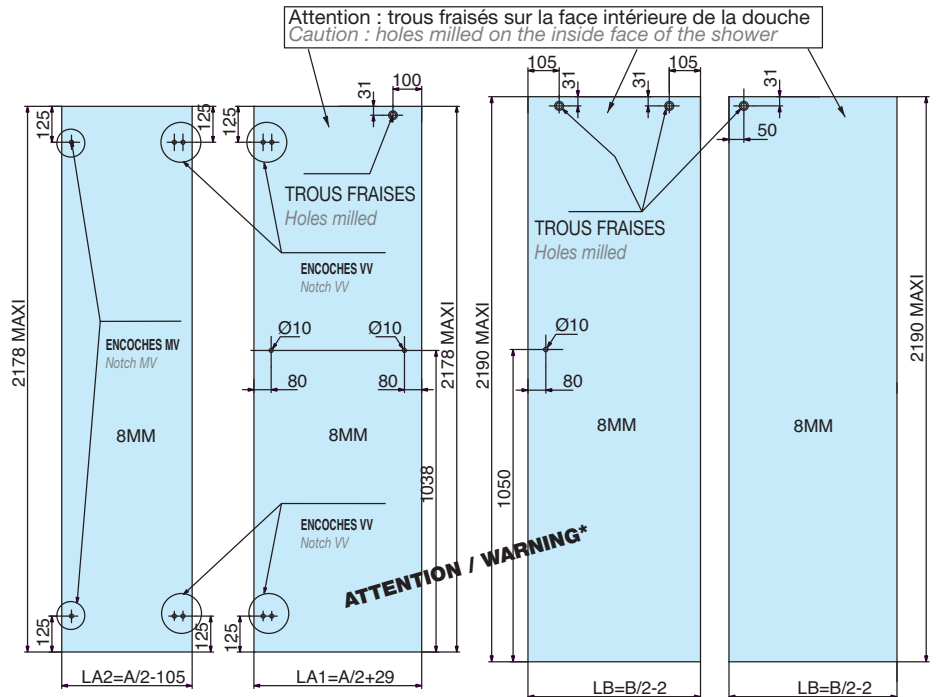
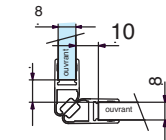
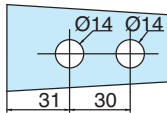

\* Plan valable uniquement pour cette configuration, pour l'autre, inverser le sens de la fraisure

Drawing only valid for this configuration, for the other, reverse the direction of countersinking

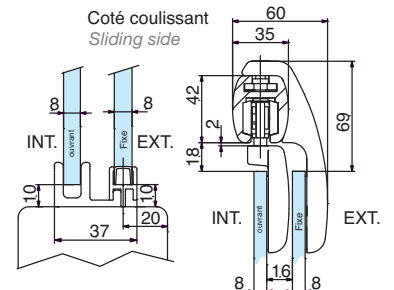
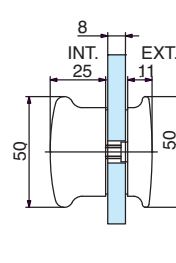
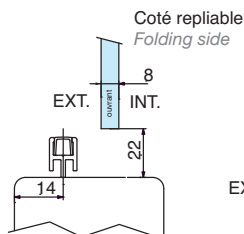
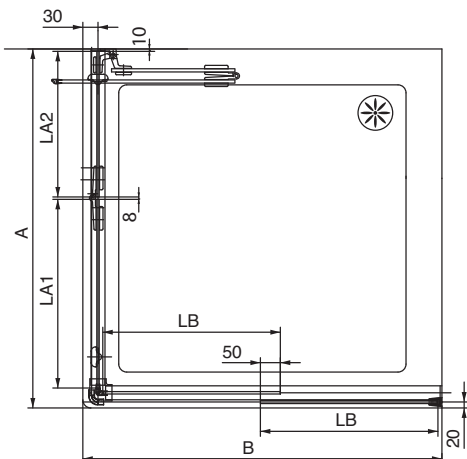

Systèmes  
coulissants  
pour douches  
*Sliding shower  
system*



Profil pour  
pare baignoires  
*Hinged profile  
for bath screens*

# Filéó

## Caractéristiques techniques

- Profil recoupable longueur 1520 mm embouts compris
- Pour verre trempé de 6 mm (non fourni)
- Montage sur 3 encoches
- Largeur de porte maxi 1000 mm
- Poids maxi par porte 25 kg
- Livré avec joint bas de porte 1809.66.0
- Réglage de l'angle de la porte par tranche de 22,5°

## Technical features

- Profile can be cut down to length 1520 mm with top and bottom end caps
- For 6 mm thick toughened glass (not supplied)
- Assembled onto 3 notches
- Door width maximum 1000 mm
- Maximum weight per door 25 kg
- Supplied with sealing strip for bottom of door 1809.66.0
- Angle of door adjustable by sections of 22,5°

## LES + PRODUITS

*The + product*

Esthétique

Grande qualité de finitions

Étanchéité optimisée

Joint passant

Système de came levante intégrée pour un dégagement aisé du joint de seuil

Attractive

High quality finishes

Optimized sealing

Full sealing strip

Rising system for a better bottom sealing strip release

## 2720.\*\*.2L15

### Références / References

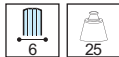

Profil articulé pour pare baignoire lg 1520 mm  
*Hinged profile for bath screens 1520 mm length*



Alu poli brillant  
*Polished aluminium*



Laqué Blanc 9010  
*Lacquered white RAL 9010*

2720.13.2L15

2720.51.2L15

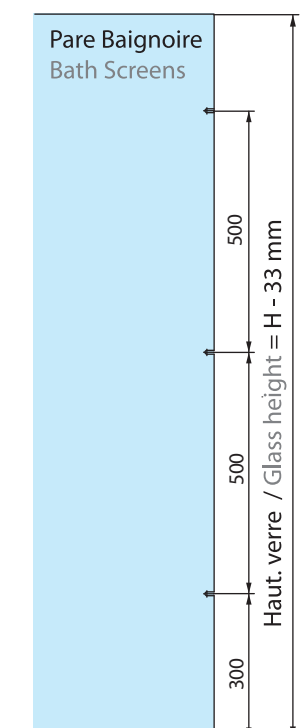
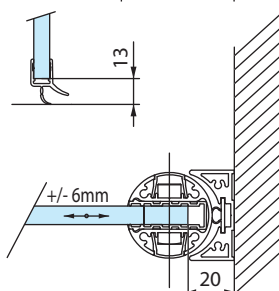
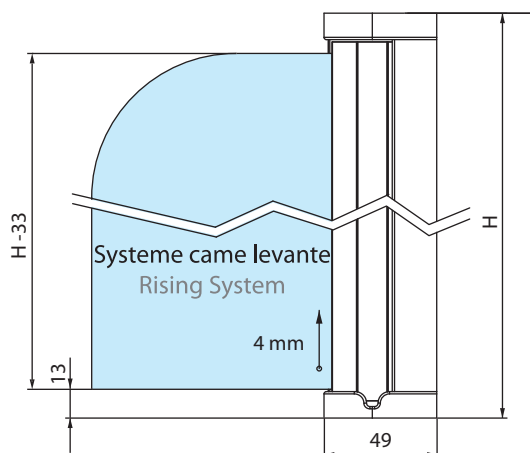
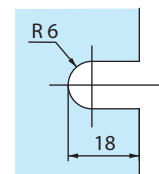
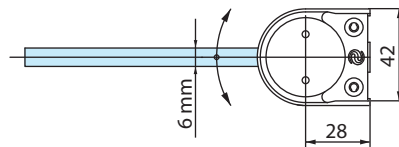



Profil pour  
pare baignoires  
*Hinged profile  
for bath screens*

**B  
A  
I  
N**



Profil pour  
pare douches  
*Hinged profile  
for shower doors*

# Filéo

## Caractéristiques techniques

- Profil recoupable longueur 2220 mm embouts compris
- Pour verre trempé de 6 ou 8 mm (non fourni)
- Montage sur 4 encoches
- Largeur de porte maxi 800 mm
- Poids maxi par porte 30 kg
- Livré avec joint bas de porte 1809.66.0
- Réglage de l'angle de la porte par tranche de 22,5°

## Technical features

- Profile can be cut down to length 2220 mm with top and bottom end caps
- For 6 or 8 mm thick toughened glass (not supplied)
- Assembled onto 4 notches
- Door width maximum 800 mm
- Maximum weight per door 30 kg
- Supplied with sealing strip for bottom of door 1809.66.0
- Angle of door adjustable by sections of 22,5°

2720.\*\*.2L22

## Références / References

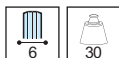

Profil articulé pour pare douche lg 2220 mm  
*Hinged profile for shower doors 2220 mm length*

2720.13.2L22 2720.51.2L22

2720.\*\*.3L22

## Références / References



Profil articulé pour pare douche lg 2220 mm  
*Hinged profile for shower doors 2220 mm length*

2720.13.3L22 2720.51.3L22

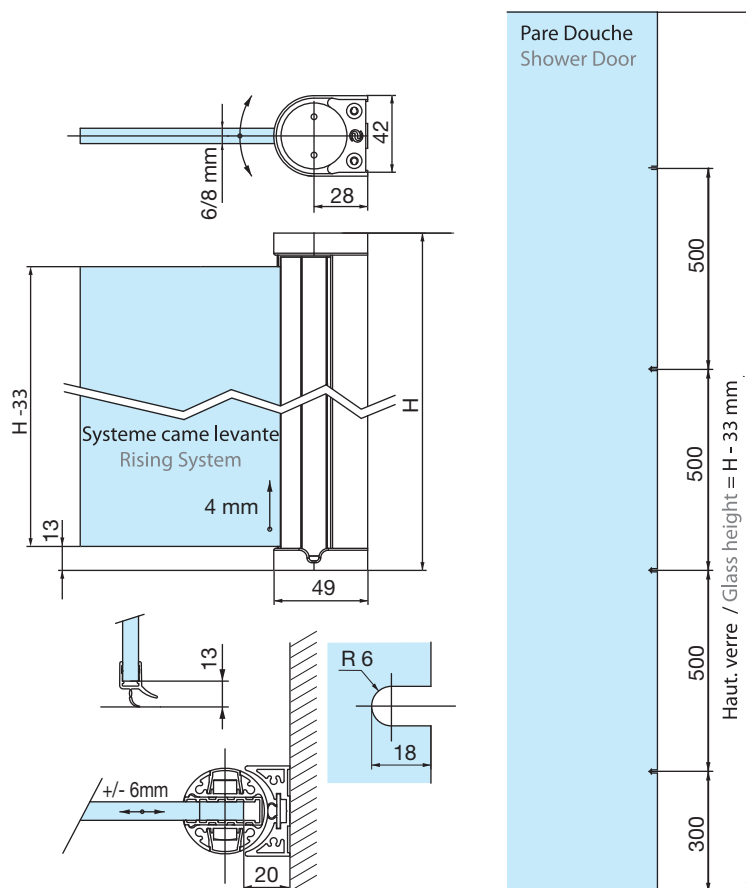
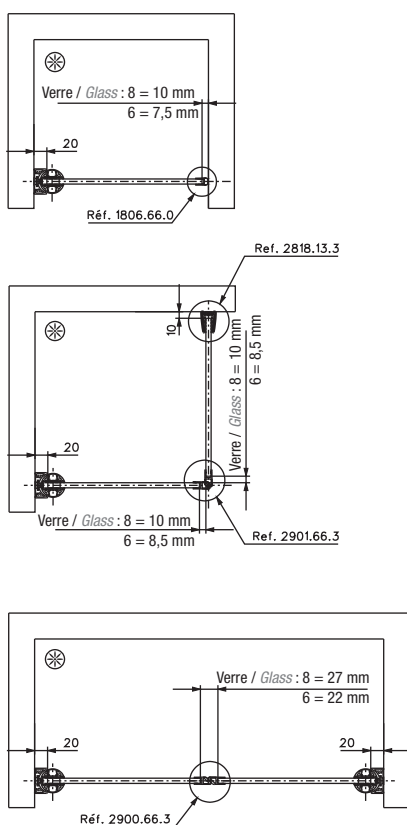



Profil pour  
pare douches  
*Hinged profile  
for shower doors*



Charnières pour  
pare douches  
*Hinges for  
shower screens*

# Kubika

## Caractéristiques techniques

- Poids maxi par porte 45 kg
- Pour verre trempé de 8 et 10 mm (non fourni)
- Montage sur 2 trous Ø 16 mm
- Ouverture à 90°
- Livrée avec vis de fixation et intercalaires
- Unité de vente : Charnière simple, conditionnée par 2
- Charnière double, conditionnée par 1

## Technical features

- Maximum weight per door 45 kg
- For 8 to 10 mm thick toughened glass (not supplied)
- Assembled onto holes Ø 16mm
- Opening through 90°
- Supplied with screws and spacers.
- Sales unit : Single hinge packaging : 2
- Glass to glass hinge packaging : 1



## SYSTÈMES BREVETÉS PATENTED SYSTEM

- Système de réglage d'angle précis
- Système anti-bruit
- Adjustment System of the door angle
- Anti-noise system

## LES + PRODUITS

*The + product*

Joint passant

Design

Réglage précis de  
l'angle de la porte

Grande qualité  
de finitions

Système anti-bruit

*Full sealing strip*

*Design*

*Precise adjustment  
of the door angle*

*High quality finishes*

*Anti-noise system*

3460.\*\*.0R

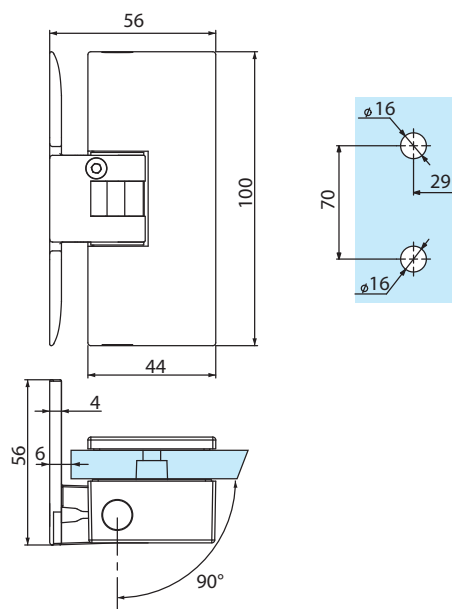

## Références / References



Chromé brillant  
*Bright chromium*



Chromé mat  
*Matt chromium*



Effet Inox  
*Stainless steel effect*

Charnière simple réglable blocage à 90°, axe déporté ouverture d'un seul côté  
*Adjustable single shower hinge 90° blocking point, offset axes opening  
on one side only*

3460.30.0R

3460.31.0R

3460.35.0R



Charnières pour  
pare douches  
*Hinges for  
shower screens*



3462.\*\*.0R

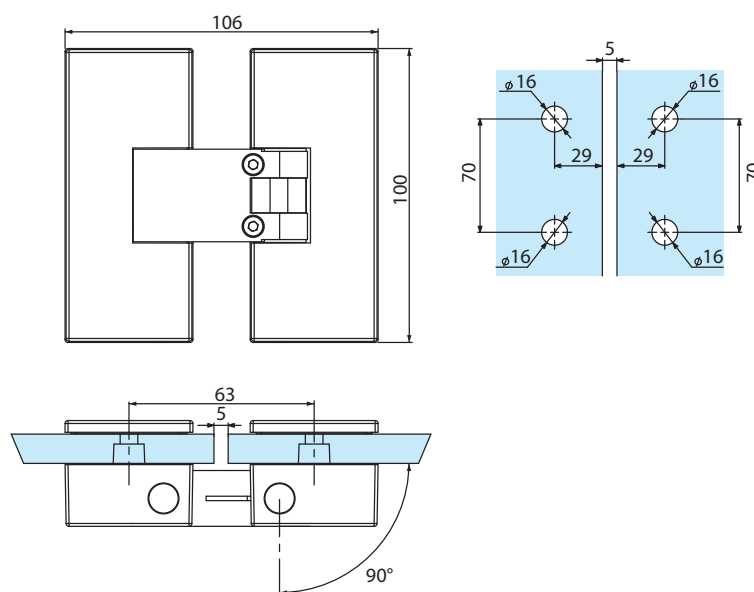

Références / References



Chromé brillant  
*Bright chromium*



Chromé mat  
*Matt chromium*



Effet Inox  
*Stainless steel effect*

Charnière double réglable blocage à 90°, axe déporté ouverture d'un seul côté  
*Adjustable double shower hinge 90° blocking point, offset axes opening  
on one side only*

3462.30.0R

3462.31.0R

3462.35.0R

Charnières pour  
pare douches  
*Hinges for  
shower screens*

# Mélora

## Caractéristiques techniques

- Poids maxi par porte 60 kg
- Pour verre trempé de 8, 10 et 12 mm
- Montage sur encoche 3560BE
- Ouverture à 180°
- Livrée avec vis de fixation
- Unité de vente : Charnière simple, conditionnée par 2  
Charnière double, conditionnée par 1

## Technical features

- Maximum weight per door 60 kg
- For 8, 10 or 12 mm thick toughened glass
- For notch 3560BE.
- Opening through 180°
- Supplied with screws.
- Sales unit : Single hinge packaging : 2  
Glass to glass hinge packaging : 1



## SYSTÈMES BREVETÉS PATENTED SYSTEM

- Système de réglage d'angle précis
- Système anti-bruit
- Adjustment System of the door angle
- Anti-noise system

## LES + PRODUITS

*The + product*

Réglage précis de  
l'angle de la porte

Grande qualité  
de finitions

Certifié TUV

Système anti-bruit

*Precise adjustment  
of the door angle*

*High quality finishes*

*TUV certified*

*Anti-noise system*

3560.\*\*.0R

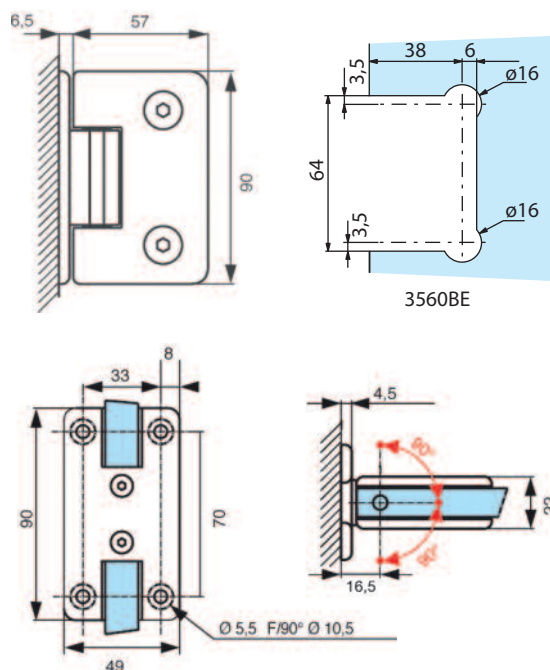

## Références / References

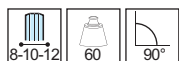

Laiton poli PVD  
Polished brass PVD



Chromé brillant  
Bright chromium



Chromé mat  
Matt chromium



Effet Inox  
Stainless steel effect

Charnière simple réglable  
blocage à 90°, 4 trous de fixation  
*Single adjustable hinge 90° blocking  
with 4 fixing points*

3560.05.0R

3560.30.0R

3560.31.0R

3560.35.0R

# 3561.\*\*.0R

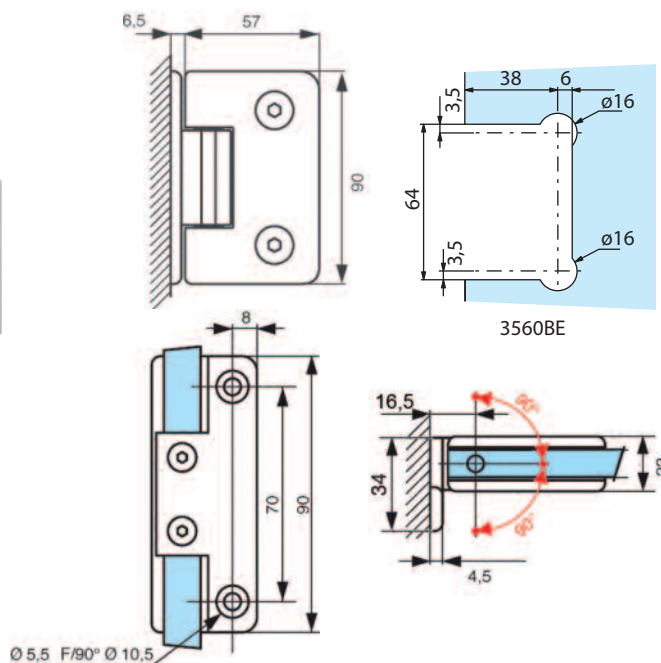

Charnières pour  
pare douches  
*Hinges for  
shower screens*

## Références / References

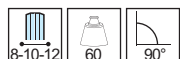

Laiton poli PVD  
*Polished brass PVD*



Chromé brillant  
*Bright chromium*



Chromé mat  
*Matt chromium*



Effet Inox  
*Stainless steel effect*

Charnière simple réglable  
blocage à 90°, 2 trous de fixation  
*Single adjustable hinge 90° blocking  
with 2 fixing points*

3561.05.0R

3561.30.0R

3561.31.0R

3561.35.0R

# 3562.\*\*.0R

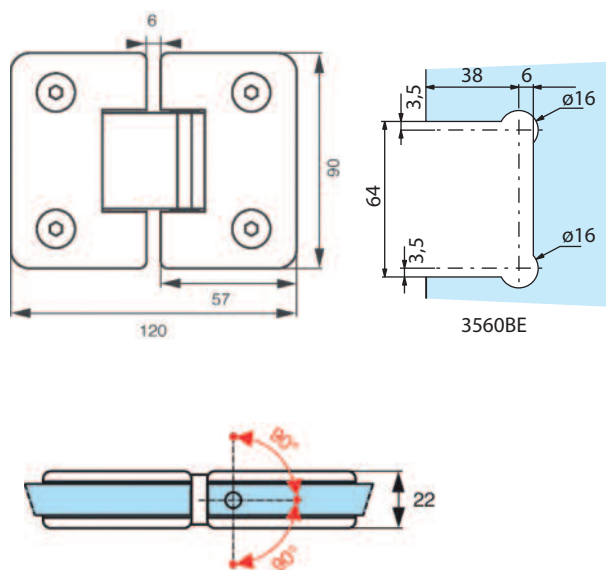

## Références / References



Laiton poli PVD  
*Polished brass PVD*



Chromé brillant  
*Bright chromium*



Chromé mat  
*Matt chromium*



Effet Inox  
*Stainless steel effect*

Charnière double verre/verre  
réglable blocage à 90°  
*Glass to glass adjustable shower  
hinge 90° blocking point*

3562.05.0R

3562.30.0R

3562.31.0R

3562.35.0R

Charnières pour  
pare douches  
*Hinges for  
shower screens*

# Mélora

3562.\*\*.2R

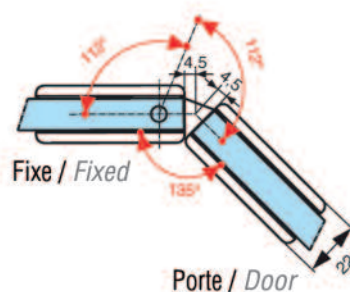
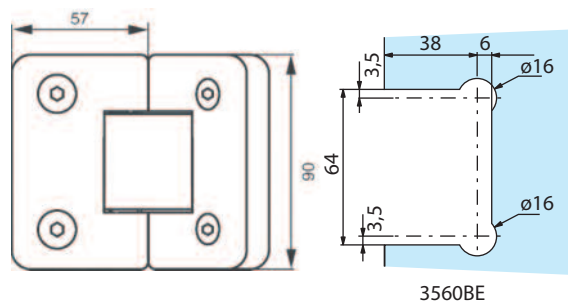
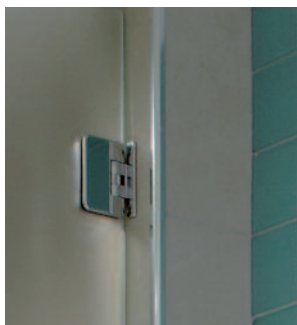

## Références / References



Charnière double verre/verre  
réglable blocage à 135°  
*Glass to glass adjustable shower  
hinge 135°blocking point*



Laiton poli PVD  
*Polished brass PVD*

3562.05.2R



Chromé brillant  
*Bright chromium*

3562.30.2R



Chromé mat  
*Matt chromium*

3562.31.2R



Effet Inox  
*Stainless steel effect*

3562.35.2R



Charnières pour  
pare douches  
*Hinges for  
shower screens*



Charnières pour  
pare douches  
*Hinges for  
shower screens*

# Mélora SQ

## Caractéristiques techniques

- Poids maxi par porte 60 kg
- Pour verre trempé de 8, 10, 12 mm
- Montage sur encoche 3560BE
- Ouverture à 180°
- Livrée avec vis de fixation
- Unité de vente : Charnière simple, conditionnée par 2  
Charnière double, conditionnée par 1

## Technical features

- Maximum weight per door 60 kg
- For 8, 10 and 12 mm thick toughened glass
- For notch 3560BE.
- Opening through 180°
- Supplied with screws
- Sales unit : Single hinge packaging : 2  
Glass to glass hinge packaging : 1



## LES + PRODUITS

*The + product*

Design

Réglage précis de  
l'angle de la porte

Grande qualité  
de finitions

Certifié TUV

Système anti-bruit

Design

Precise adjustment  
of the door angle

High quality finishes

TUV certified

Anti-noise system



**SYSTÈMES BREVETÉS  
PATENTED SYSTEM**

- Système de réglage d'angle précis
- Système anti-bruit
- Adjustment System of the door angle
- Anti-noise system

**3560.\*\*.ORSQ**

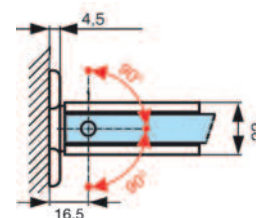
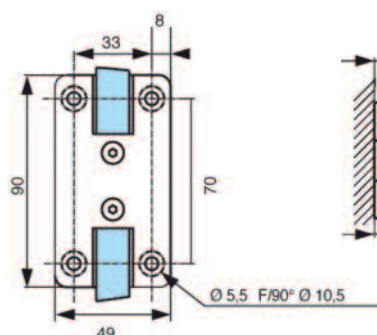
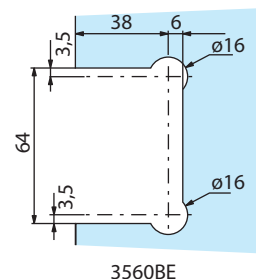
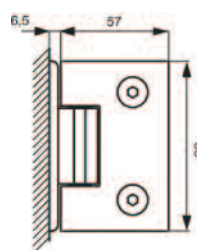

## Références / References



Chromé brillant  
*Bright chromium*



Chromé mat  
*Matt chromium*



Effet Inox  
*Stainless steel effect*

Charnière simple réglable blocage à 90°, 4 trous de fixation  
*Single adjustable hinge 90° blocking with 4 fixing points*

**3560.30.ORSQ**

**3560.31.ORSQ**

**3560.35.ORSQ**

# 3561.\*\*.0RSQ

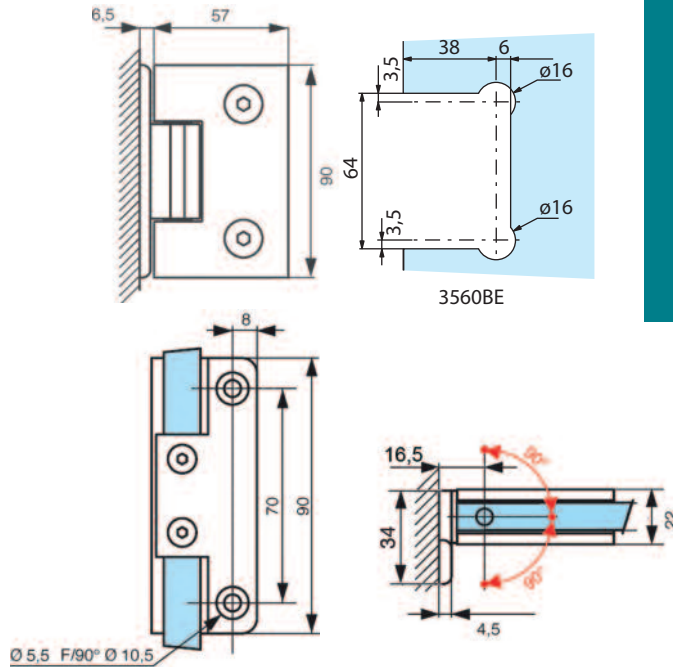

Charnières pour  
pare douches  
*Hinges for  
shower screens*

## Références / References



Chromé brillant  
*Bright chromium*



Chromé mat  
*Matt chromium*



Effet Inox  
*Stainless steel effect*

Charnière simple réglable blocage à 90°, 2 trous de fixation  
*Single adjustable hinge 90° blocking with 2 fixing points*

3561.30.0RSQ

3561.31.0RSQ

3561.35.0RSQ

# 3562.\*\*.0RSQ

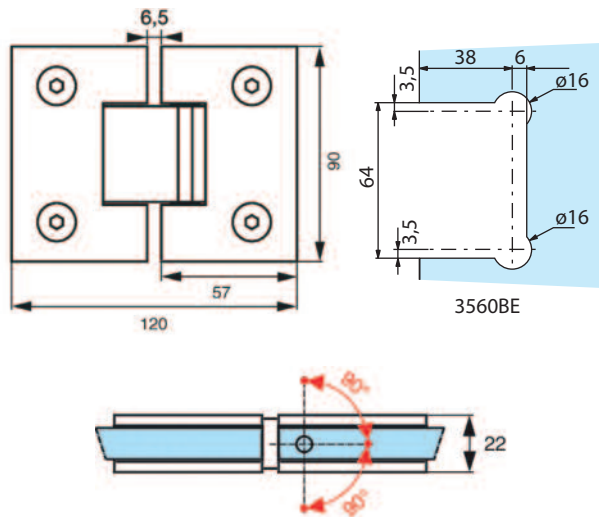

## Références / References



Chromé brillant  
*Bright chromium*



Chromé mat  
*Matt chromium*



Effet Inox  
*Stainless steel effect*

Charnière double verre/verre réglable blocage à 90°  
*Glass to glass adjustable shower hinge 90° blocking point*

3562.30.0RSQ

3562.31.0RSQ

3562.35.0VSQ

Charnières pour  
pare douches  
*Hinges for  
shower screens*

# Marine

## Caractéristiques techniques

- Poids maxi par porte 60 kg
- Pour verre trempé de 8 et 10 mm
- Montage sur encoche 3260BE
- Ouverture à 180°
- Livrée avec vis de fixation
- Unité de vente : Charnière simple, conditionnée par 2  
Charnière double, conditionnée par 1

## Technical features

- Maximum weight per door 60 kg
- For 8 and 10 mm thick toughened glass
- For notch 3260BE
- Opening through 180°
- Supplied with screws and spacers
- Sales unit : Single hinge packaging : 2  
Glass to glass hinge packaging : 1



## SYSTÈMES BREVETÉS PATENTED SYSTEM

- Système de réglage d'angle précis
- Système anti-bruit
- Adjustment System of the door angle
- Anti-noise system

## LES + PRODUITS

*The + product*

Design

Réglage précis de  
l'angle de la porte

Grande qualité  
de finitions

Certifié TUV

Système anti-bruit

Design

Precise adjustment  
of the door angle

High quality finishes

TUV certified

Anti-noise system

3260.\*\*.0R

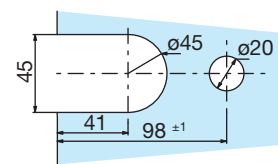
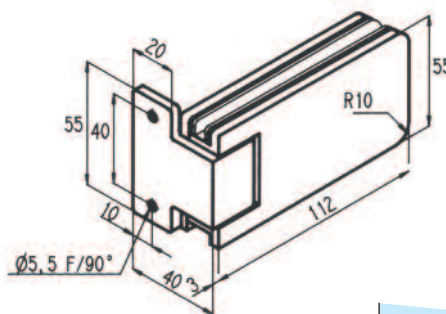

3260BE

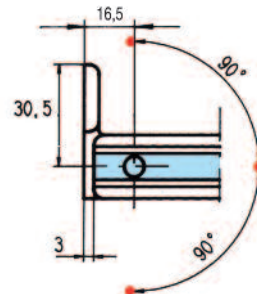

## Références / References



Laiton poli PVD  
Polished brass PVD



Chromé brillant  
Bright chromium



Chromé mat  
Matt chromium



Effet Inox  
Stainless steel effect



Laqué blanc 9010  
Lacquered white RAL 9010

Charnière simple réglable  
blocage à 90°, 2 trous de fixation  
*Single adjustable hinge 90°  
blocking with 2 fixing points*

3260.05.0R

3260.30.0R

3260.31.0R

3260.35.0R

3260.51.0R



# 3261.\*\*.0R

Charnières pour  
pare douches  
*Hinges for  
shower screens*

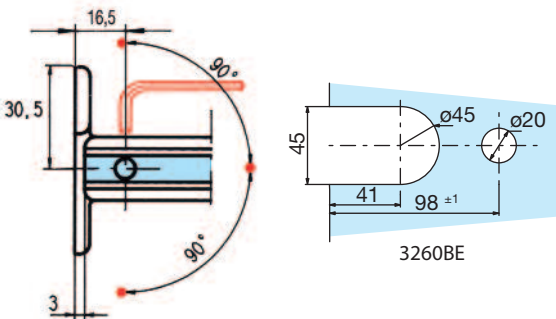
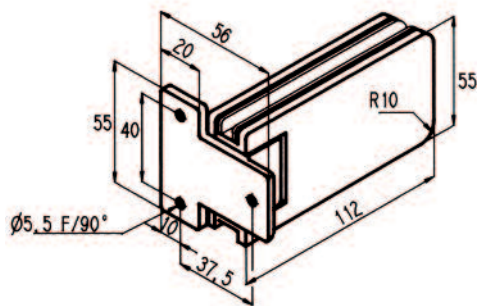

Références / References

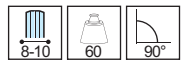

-   
 Laiton poli PVD  
*Polished brass PVD*
-   
 Chromé brillant  
*Bright chromium*
-   
 Chromé mat  
*Matt chromium*
-   
 Effet Inox  
*Stainless steel effect*
-   
 Laqué blanc 9010  
*Lacquered white RAL 9010*

Charnière simple réglable  
blocage à 90°, 3 trous de fixation  
*Single adjustable hinge 90°  
blocking with 3 fixing points*

- 3261.05.0R
- 3261.30.0R
- 3261.31.0R
- 3261.35.0R
- 3261.51.0R

# 3262.\*\*.0R

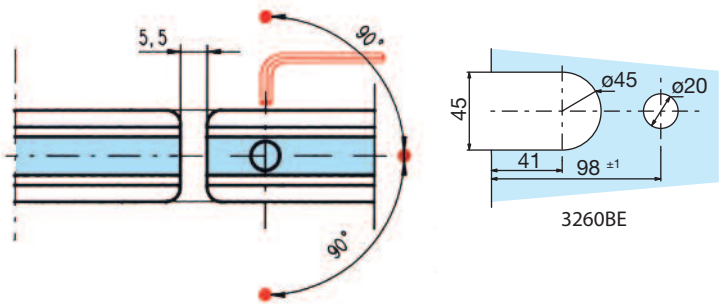
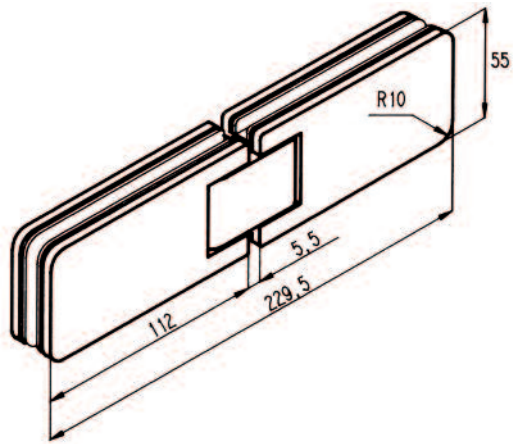

Références / References

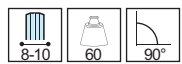

-   
 Laiton poli PVD  
*Polished brass PVD*
-   
 Chromé brillant  
*Bright chromium*
-   
 Chromé mat  
*Matt chromium*
-   
 Effet Inox  
*Stainless steel effect*
-   
 Laqué blanc 9010  
*Lacquered white RAL 9010*

Charnière double verre/verre réglable  
blocage à 90°  
*Glass to glass adjustable shower  
hinge 90° blocking point*

- 3262.05.0R
- 3262.30.0R
- 3262.31.0R
- 3262.35.0R
- 3262.51.0R



Charnières pour  
pare douches  
*Hinges for  
shower screens*

3262.\*\*.2R

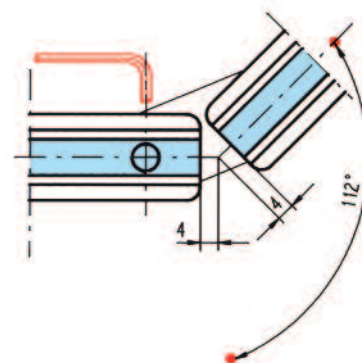
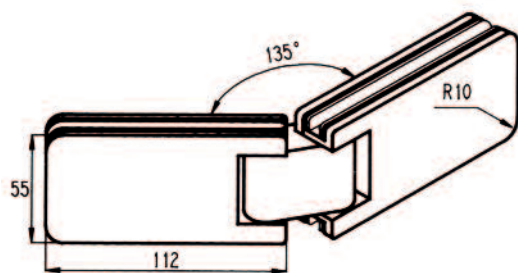
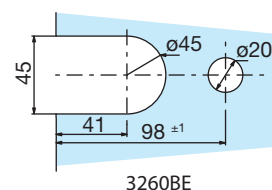

Références / References



Laiton poli PVD  
Polished brass PVD



Chromé brillant  
Bright chromium



Chromé mat  
Matt chromium



Effet Inox  
Stainless steel effect



Laqué blanc 9010  
Lacquered white RAL 9010

Charnière double verre/verre réglable  
blocage à 135°  
*Glass to glass adjustable shower hinge  
135° blocking point*

3262.05.2R

3262.30.2R

3262.31.2R

3262.35.2R

3262.51.2R

# 3264.\*\*.0R

## Charnières pour pare douches *Hinges for shower screens*

### Caractéristiques techniques

- Montage sur encoche 3264BE pour le volume mobile et 3260BE pour le volume fixe
- Pour verre de 8 mm B = 8 mm C = 7 mm
- Pour verre de 10 mm B = 7 mm C = 6 mm

### Technical features

- For mobile panel on notch 3264BE and 3260BE for fixed panel
- For 8 mm glass B = 8 mm C = 7 mm
- For 10 mm glass B = 7 mm C = 6 mm

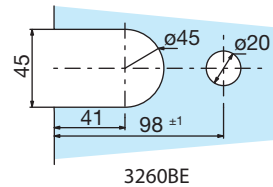
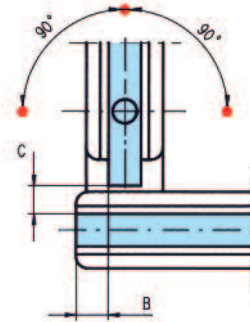
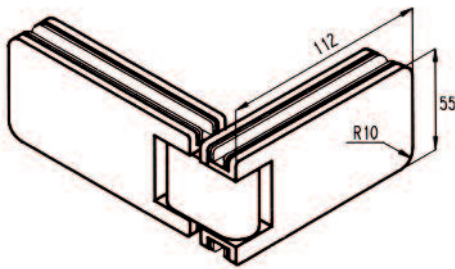
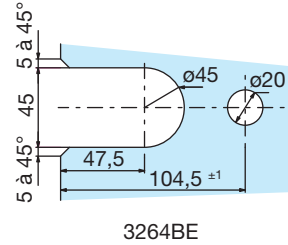
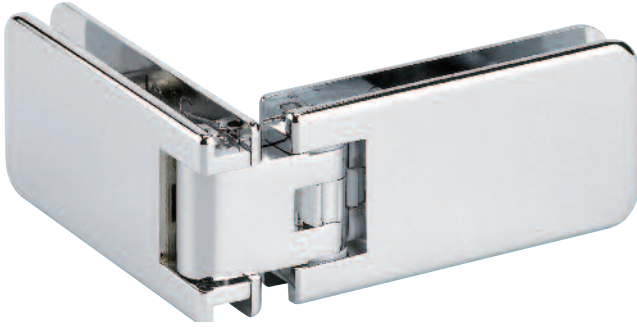

### Références / References



Laiton poli PVD  
Polished brass PVD



Chromé brillant  
Bright chromium



Chromé mat  
Matt chromium



Effet Inox  
Stainless steel effect



Laqué blanc 9010  
Lacquered white RAL 9010

Charnière double d'angle, réglable  
Corner adjustable shower hinge

3264.05.0R

3264.30.0R

3264.31.0R

3264.35.0R

3264.51.0R

Charnières  
réglables pour  
pare douche  
*Adjustable hinges  
for shower screens*

# Marine SQ

## Caractéristiques techniques

- Poids maxi par porte 60 kg
- Pour verre trempé de 8 et 10 mm
- Montage sur encoche 3660BE
- Ouverture à 180°
- Livrée avec vis de fixation
- Unité de vente : Charnière simple, conditionnée par 2  
Charnière double, conditionnée par 1

## Technical features

- Maximum weight per door 60 kg
- For 8 to 10 mm thick toughened glass
- For notch 3660BE
- Opening through 180°
- Supplied with screws and spacers
- Sales unit : Single hinge packaging : 2  
Glass to glass hinge packaging : 1



## LES + PRODUITS

*The + product*

Design

Réglage précis  
de l'angle de la porte

Grande qualité  
de finitions

Certifié TUV

Système anti-bruit

Design

Precise adjustment  
of the door angle

High quality finishes

TUV certified

Anti-noise system



SYSTÈMES BREVETÉS  
PATENTED SYSTEM

- Système de réglage d'angle précis
- Système anti-bruit
- Adjustment System of the door angle
- Anti-noise system

3660.\*\*.ORSQ

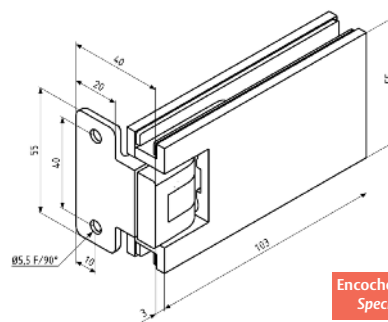

Encoche spécifique  
Specific notch

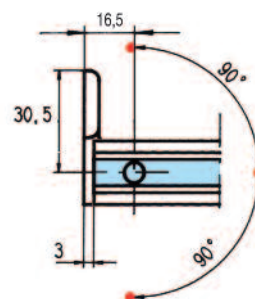
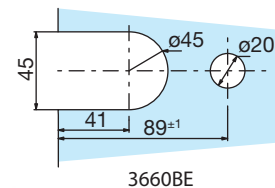

Chromé brillant  
Bright chromium



Chromé mat  
Matt chromium

Charnière simple réglable blocage à 90°, 2 trous de fixation  
Single adjustable hinge 90° blocking with 2 fixing points

3660.30.ORSQ 3660.31.ORSQ

3662.\*\*.0RSQ

Charnières réglables pour pare douche  
Adjustable hinges for shower screens

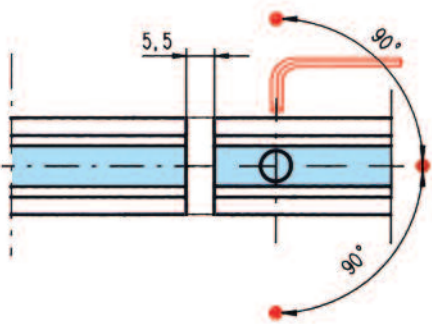
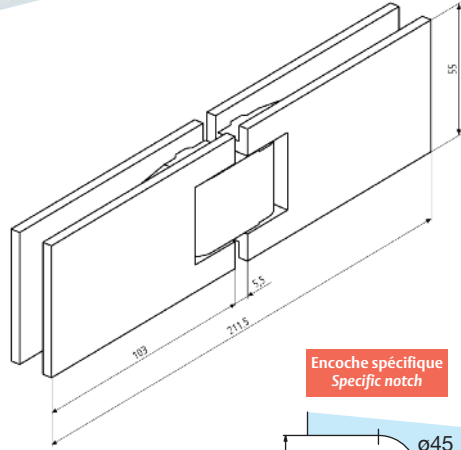

Encoche spécifique  
Specific notch

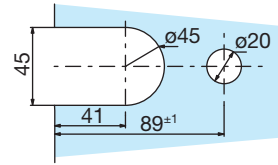

3660BE



Chromé brillant  
Bright chromium



Chromé mat  
Matt chromium

Charnière double verre/verre réglable blocage à 90°  
Glass to glass adjustable shower hinge 90° blocking point

3662.30.0RSQ 3662.31.0RSQ



Charnières  
réglables pour  
pare douche  
*Adjustable hinges  
for shower screens*

# Carréa

## Caractéristiques techniques

- Systèmes brevetés
- Nouveau design
- Réglage précis de l'angle de la porte breveté
- Système anti-bruit breveté
- Pour porte jusqu'à 45kg
- Ouverture à 180°
- Point de rotation centré, va et vient possible
- Grande qualité de finitions
- Testé suivant la norme EN 1670 grade 5
- Garantie 5 ans

## Technical features

- Patented system
- New design
- Patented precise adjustment of the door angle
- Patented anti-noise system
- For doors up to 45kg
- Opening through 180°
- Centered pivot-point, possible swing door
- High quality finishes
- Tested according to the standard EN 1670 grade 5
- 5 years warranty

## LES + PRODUITS

*The + product*

Nouveau design

Réglage précis  
de l'angle de la porte

Grande qualité  
de finitions

Système anti-bruit

*New design*

*Precise adjustment  
of the door angle*

*High quality finishes*

*Anti-noise system*



**SYSTÈMES BREVETÉS**  
**PATENTED SYSTEM**

- Système de réglage d'angle précis
- Système anti-bruit
- *Adjustment System of the door angle*
- *Anti-noise system*

3760.\*\*.ORSQ

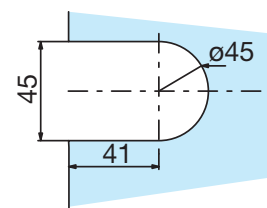
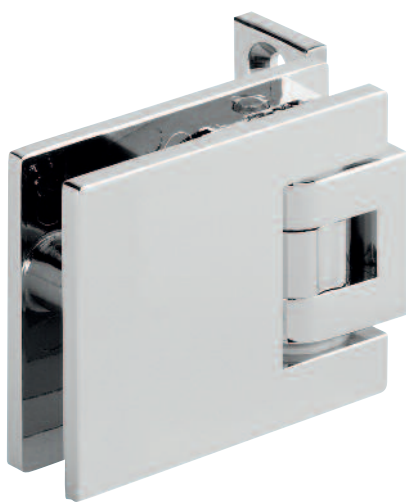

3760BE

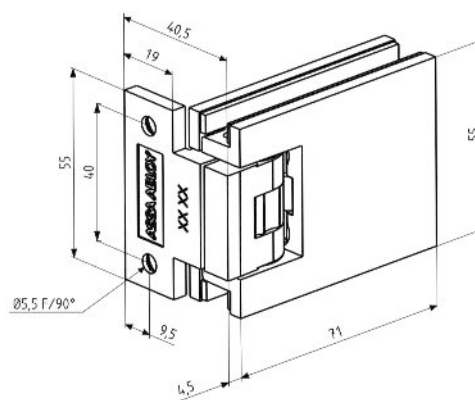

Chromé brillant  
*Bright chromium*



Chromé mat  
*Matt chromium*

Charnière simple réglable blocage à 90°, 2 trous de fixation  
*Single adjustable hinge 90° blocking with 2 fixing points*

3760.30.ORSQ 3760.31.ORSQ

3762.\*\*.0RSQ

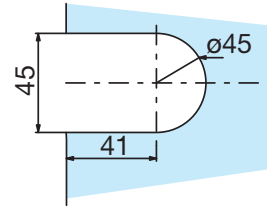
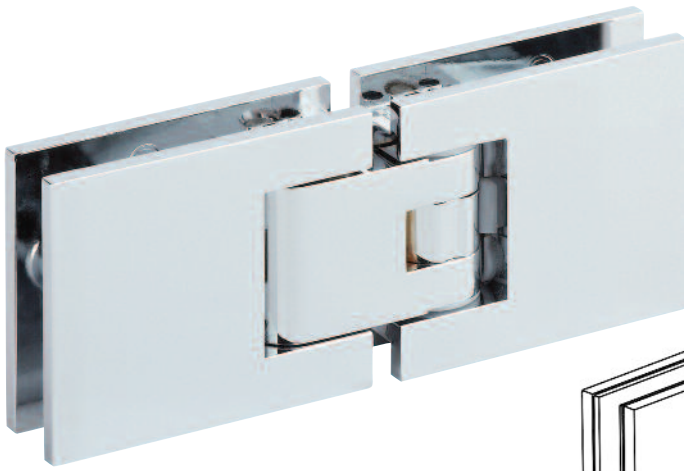

3760BE

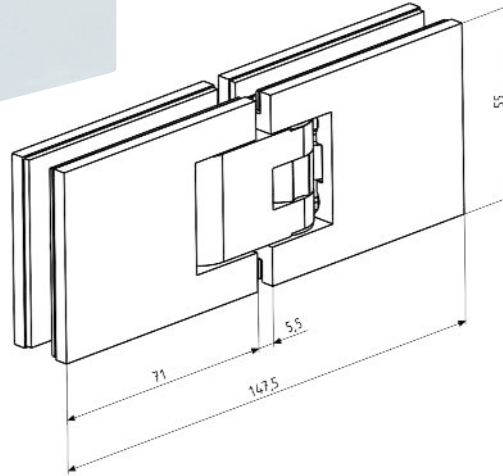

Charnières  
réglables pour  
pare douche  
*Adjustable hinges  
for shower screens*



Chromé brillant  
Bright chromium



Chromé mat  
Matt chromium

Charnière double verre/verre réglable blocage à 90°  
*Glass to glass adjustable shower hinge 90° blocking point*

3762.30.0RSQ 3762.31.0RSQ

Charnières pour  
pare douches  
*Hinges for  
shower screens*

# Maréva

## Caractéristiques techniques

- Poids maxi par porte 40 kg
- Pour verre trempé de 6 et 8 mm
- Montage sur encoche 3160BE
- Ouverture à 180°
- Livrée avec vis de fixation et intercalaires
- Unité de vente : Charnière simple, conditionnée par 2  
Charnière double, conditionnée par 1

## Technical features

- Maximum weight per door 40 kg
- For 6 and 8 mm thick toughened glass
- For notch 3160BE
- Opening through 180°
- Supplied with screws and spacers
- Sales unit : Single hinge packaging : 2  
Glass to glass hinge packaging : 1



## SYSTÈMES BREVETÉS PATENTED SYSTEM

- Système de réglage d'angle précis
- Système anti-bruit
- Adjustment System of the door angle
- Anti-noise system

## LES + PRODUITS

*The + product*

Réglage précis de  
l'angle de la porte

Grande qualité  
de finitions

Compact

Certifié TUV

Système anti-bruit

*Precise adjustment  
of the door angle*

*High quality finishes*

Compact

TUV certified

Anti-noise system

3160.\*\*.0R

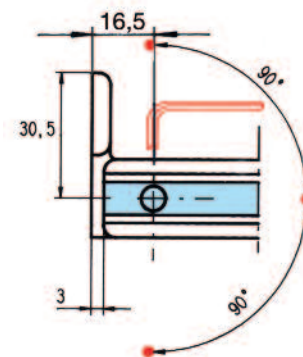
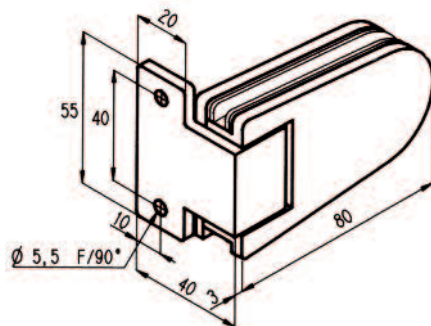
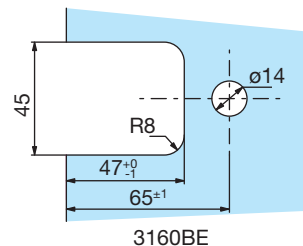

## Références / References



Laiton poli PVD  
Polished brass PVD



Chromé brillant  
Bright chromium



Chromé mat  
Matt chromium



Effet Inox  
Stainless steel effect



Laqué blanc 9010  
Lacquered white RAL 9010

Charnière simple réglable blocage à 90°, 3160.05.0R  
2 trous de fixation

3160.30.0R

3160.31.0R

3160.35.0R

3160.51.0R

*Single adjustable hinge 90° blocking  
with 2 fixing points*

# 3161.\*\*.0R

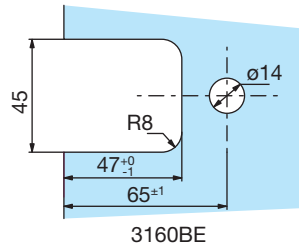

Charnières pour  
pare douches  
*Hinges for  
shower screens*

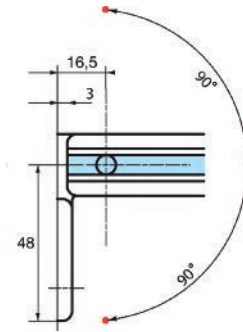
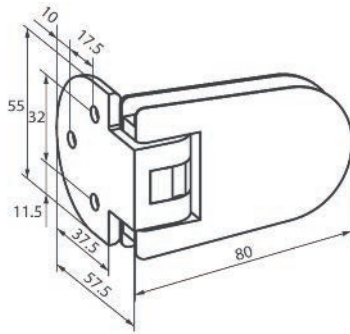

### Références / References



- Laiton poli PVD  
Polished brass PVD
- Chromé brillant  
Bright chromium
- Chromé mat  
Matt chromium
- Effet Inox  
Stainless steel effect
- Laqué blanc 9010  
Lacquered white RAL 9010

Charnière simple réglable blocage à 90° **3161.05.0R** **3161.30.0R** **3161.31.0R** **3161.35.0R** **3161.51.0R**  
 3 trous de fixation  
*Single adjustable hinge 90° blocking  
 with 3 fixing points*

# 3162.\*\*.0R

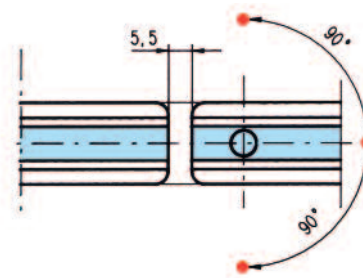
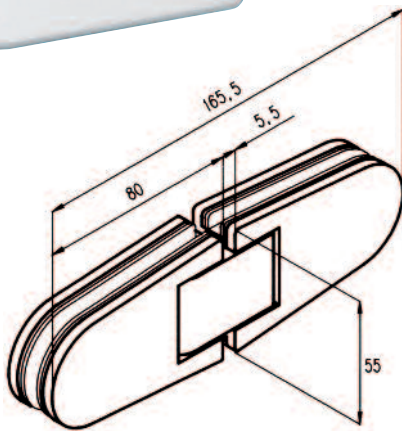
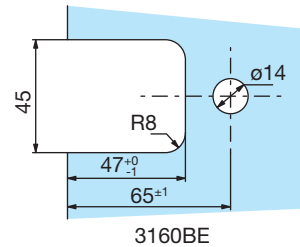

### Références / References



- Laiton poli PVD  
Polished brass PVD
- Chromé brillant  
Bright chromium
- Chromé mat  
Matt chromium
- Effet Inox  
Stainless steel effect
- Laqué blanc 9010  
Lacquered white RAL 9010

Charnière double verre/verre réglable blocage à 90° **3162.05.0R** **3162.30.0R** **3162.31.0R** **3162.35.0R** **3162.51.0R**  
*Glass to glass adjustable  
 shower hinge 90° blocking point*



Charnières pour  
pare douches  
Hinges for  
shower screens

## 3162.\*\*.2R

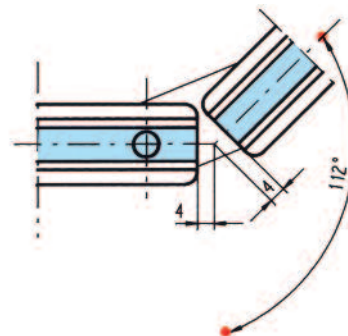
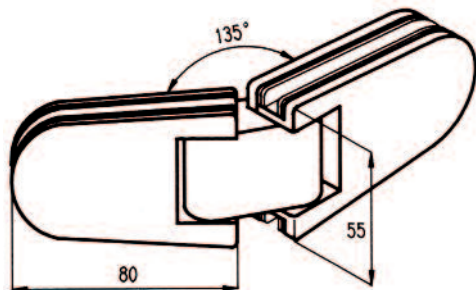
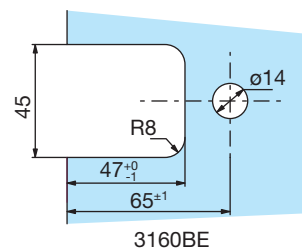

### Références / References



Laiton poli PVD  
Polished brass PVD



Chromé brillant  
Bright chromium



Chromé brillant  
Bright chromium



Chromé mat  
Matt chromium



Laqué blanc 9010  
Lacquered white RAL 9010

Charnière double verre/verre réglable  
blocage à 135°  
Glass to glass adjustable shower  
hinge 135° blocking point

3162.05.2R

3162.30.2R

3162.31.2R

3162.35.2R

3162.51.2R

## 3163.\*\*.0R

### Caractéristiques techniques

- Permet de replier le 2ème volume sur le 1er volume
- Enables 2nd glass panel to be folded back over 1st panel

### Technical features

- Enables 2nd glass panel to be folded back over 1st panel

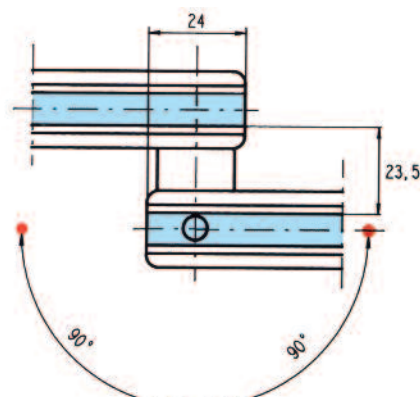
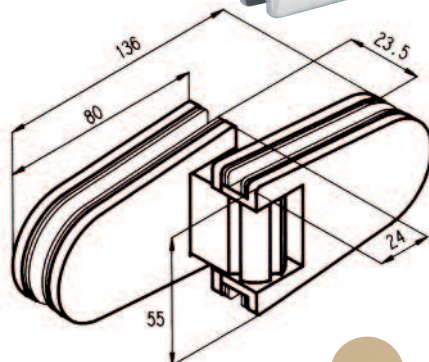
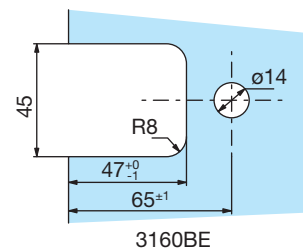
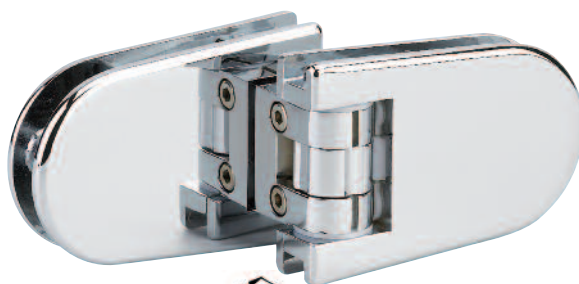

### Références / References



Laiton poli PVD  
Polished brass PVD



Chromé brillant  
Bright chromium



Chromé mat  
Matt chromium



Effet Inox  
Stainless steel effect



Laqué blanc 9010  
Lacquered white RAL 9010

Charnière double verre/verre réglable,  
à recouvrement  
Overlapping glass to glass adjustable  
shower hinge

3163.05.0R

3163.30.0R

3163.31.0R

3163.35.0R

3163.51.0R

# 3164.\*\*.0R

## Charnières pour pare douches *Hinges for shower screens*

### Caractéristiques techniques

- Montage sur encoche 3164BE pour le volume mobile et 3160BE pour le volume fixe

### Technical features

- For mobile panel on notch 3164BE, for fixed panel 3160BE

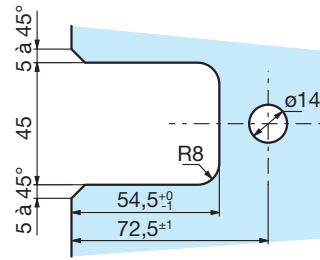
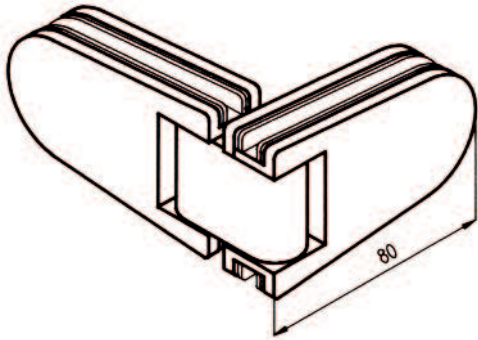
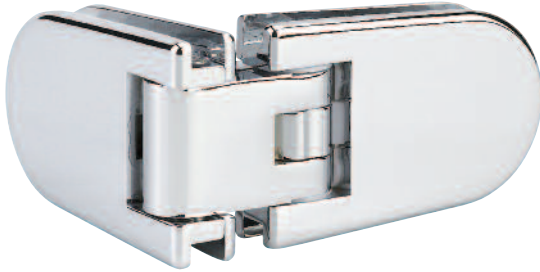

3164BE

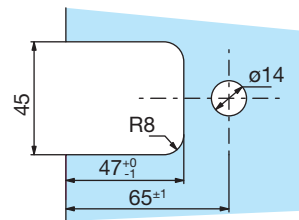
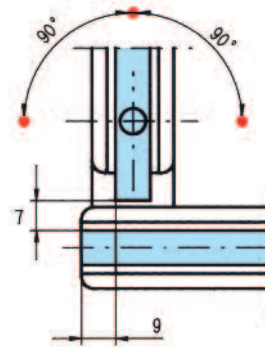

3160BE

### Références / References



Laiton poli PVD  
Polished brass PVD



Chromé brillant  
Bright chromium



Chromé mat  
Matt chromium



Effet Inox  
Stainless steel effect



Laqué blanc 9010  
Lacquered white RAL 9010

Charnière double verre/verre  
réglable, à recouvrement  
*Overlapping glass to glass adjustable  
shower hinge*

**3164.05.0R**

**3164.30.0R**

**3164.31.0R**

**3164.35.0R**

**3164.51.0R**

Cales pour  
charnières  
*Shims for hinges*

**Caractéristiques techniques**

- Cas d'utilisation avec les joints translucides séries 1801, 1806 ou pour compenser l'épaisseur de la faïence en partie haute
- Unité de vente : 10 cales

**Technical features**

- Recommended in conjunction with translucent sealing strips 1801, 1806 or to compensate the thickness of tiles on top part of wall
- Sold by 10

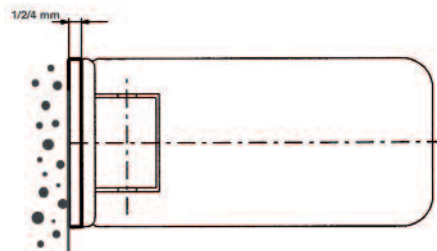
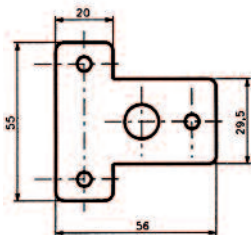
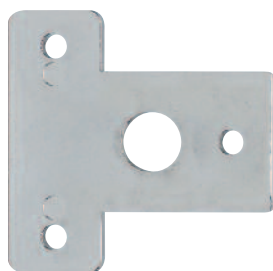

**2814.\*\*.1**

**Références / References**

10 cales épaisseur 4 mm pour charnière pour série 3261  
10 shims, 4 mm thick for hinge series 3261



Chromé brillant  
Bright chromium



Chromé mat  
Matt chromium

**2814.30.1**

**2814.31.1**

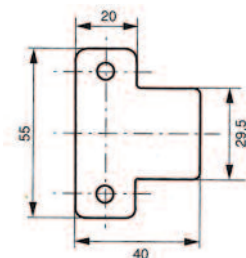

**2814.\*\*.2**

**Références / References**

10 cales épaisseur 4 mm pour charnière pour série 3160 et 3260  
10 shims, 4 mm thick for hinge series 3160 and 3260



Chromé brillant  
Bright chromium



Chromé mat  
Matt chromium

**2814.30.2**

**2814.31.2**

**2814.99.3**

**Références / References**

10 cales épaisseur 1 mm pour charnières pour séries 3260/3261/3160  
10 shims, 1 mm thick for hinge series 3260/3261/3160

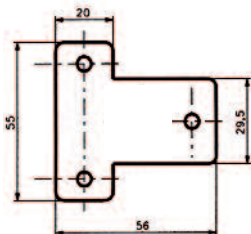

**2814.99.4**

**Références / References**

10 cales épaisseur 2 mm pour charnières pour séries 3260/3261/3160  
10 shims, 2 mm thick for hinge series 3260/3261/3160

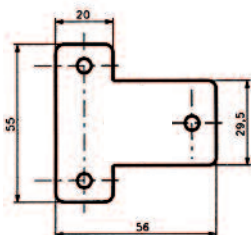

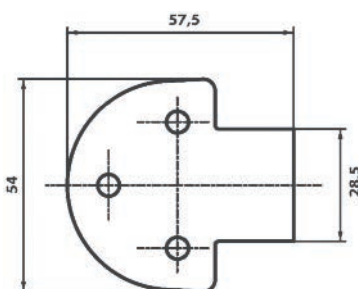

**2814.\*\*.7**

**Références / References**

10 cales épaisseur 4 mm pour charnière pour série 3161  
10 shims, 4 mm thick for hinge series 3161



Chromé brillant  
Bright chromium

**2814.30.7**



Chromé mat  
Matt chromium

**2814.31.7**

**2814.99.5**

**Références / References**

10 cales épaisseur 1 mm pour charnières pour série 3161  
10 shims, 1 mm thick for hinge series 3161

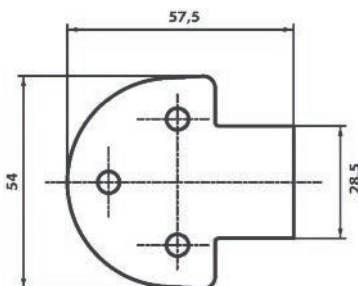



Charnières pour  
pare douches  
*Hinges for  
shower screens*

# Coralia

## Caractéristiques techniques générales

- Poids maxi par porte 25 kg
- Pour verre trempé de 6 et 8 mm
- Montage sur trous
- Ouverture à 90°
- Livrée avec vis de fixation et intercalaires
- Unité de vente : 1 charnière, conditionnée par 2

## General technical features

- Maximum weight per door 25 kg
- For 6 and 8 mm thick toughened glass
- Assembled onto holes
- Opening through 90°
- Supplied with screws and spacers
- Sold per unit, packed in pairs

## 3060.\*\*.0

### Caractéristiques techniques

- Montage sur encoche 3060E
- Blocage du volume par joints magnétiques
- Ouverture possible jusqu'à 170°

### Technical features

- For notch 3060E
- Glass door panel blocking by magnetic strips
- Opening through 170°

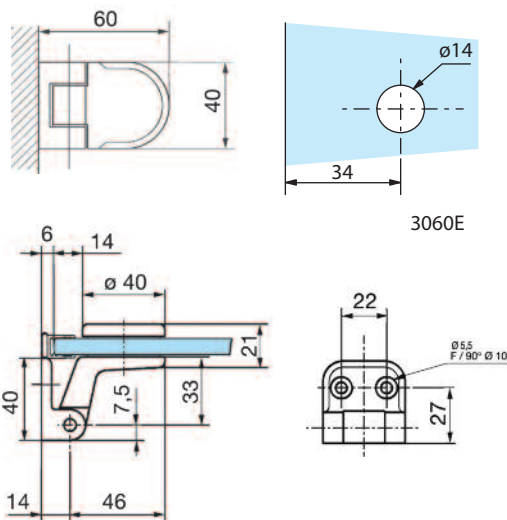
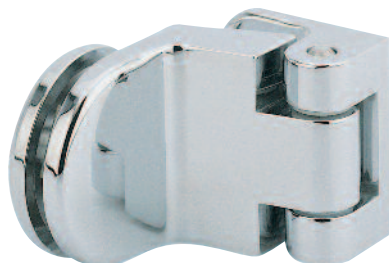

### Références / References



Laiton poli PVD Polished brass PVD	Chromé brillant Bright chromium	Chromé mat Matt chromium	Effet Inox Stainless steel effect
3060.05.0	3060.30.0	3060.31.0	3060.35.0

Charnière simple action à  
2 trous de fixation  
*Single hinge with 2 fixing points,  
without blocking point*

## 3069.\*\*.0

### Caractéristiques techniques

- Montage sur encoche 3069E
- Utilisation avec joints bourrelets et joints magnétiques

### Technical features

- For notch 3069E
- Used with compressible profile and magnetic sealing strips

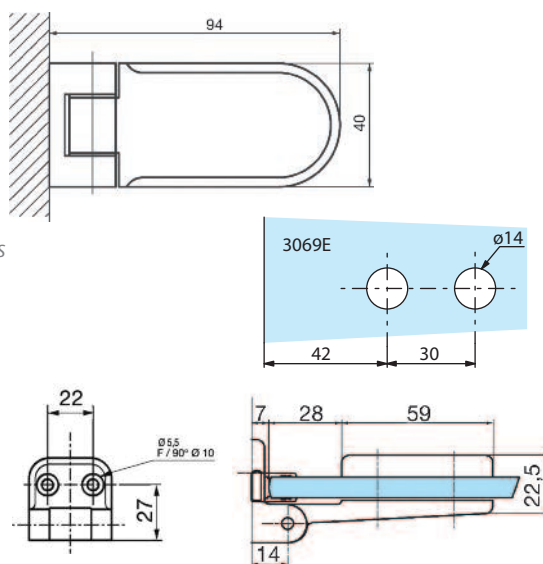

### Références / References



Laiton poli PVD Polished brass PVD	Chromé brillant Bright chromium	Chromé mat Matt chromium	Effet Inox Stainless steel effect
3069.05.0	3069.30.0	3069.31.0	3069.35.0

Charnière simple action  
à 2 trous de fixation  
*Single hinge with 2 fixing points,  
without blocking point*

## LES + PRODUITS

*The + product*

Grande qualité  
de finitions

3060 et 3063  
compatible verre  
bombée

Discret

Certifié TUV

*High quality finishes*

3060 and 3063  
compatible with  
curved glass

Discreet

TUV certified

# 3062.\*\*.0

## Caractéristiques techniques

- Montage sur encoche 3062E180 pour 2 volumes à 180°
- Montage sur encoche 3062E135 pour 2 volumes à 135°
- Utilisation avec joints bourrelets et joints magnétiques

## Technical features

- 180° blocking point 2 glass panels see notch 3062E180
- 135° blocking point 2 glass panels see notch 3062E135
- Used with compressible profile and magnetic sealing strips

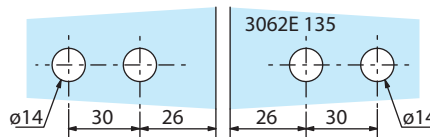
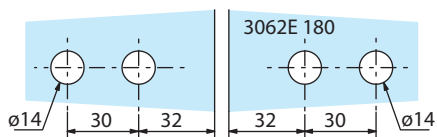
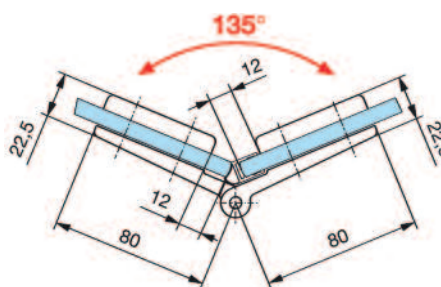
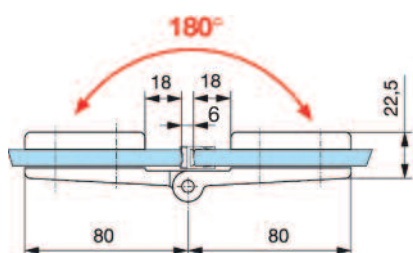
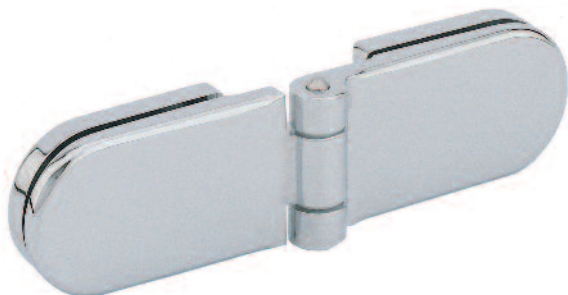

## Références / References



Laiton poli PVD  
Polished brass PVD



Chromé brillant  
Bright chromium



Chromé mat  
Matt chromium



Effet Inox  
Stainless steel effect

Charnière double,  
simple action  
*Glass to glass shower hinge,  
one way opening*

3062.05.0

3062.30.0

3062.31.0

3062.35.0

**Caractéristiques techniques**

- Volume fixe montage sur encoche 3062E135
- Volume mobile montage sur trous Ø 14 mm à 106 mm du bord du volume pour le recouvrement avec le volume fixe
- Si recouvrement plus important augmenter la côte de 106 mm
- Utilisation avec joints bourrelets et joints magnétiques

**Technical features**

- Fixed glass panel see notch 3062E135
- For door aligned with fixed panel use holes Ø 14 mm at 106 mm of the edge glass
- In case of overlapping of glass panels increase by 106 mm
- Used with compressible profile and magnetic sealing strips

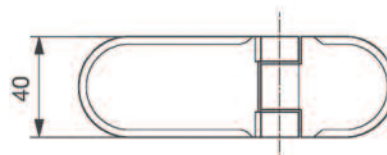
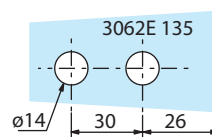
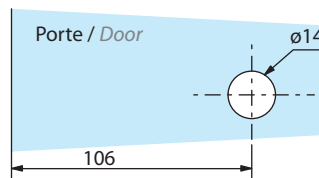
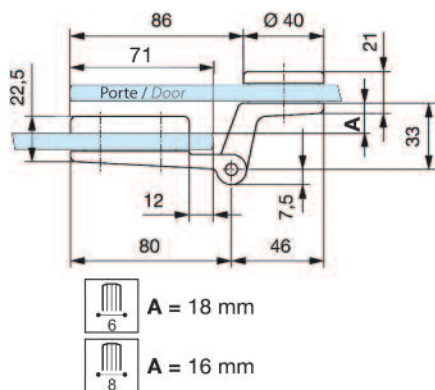
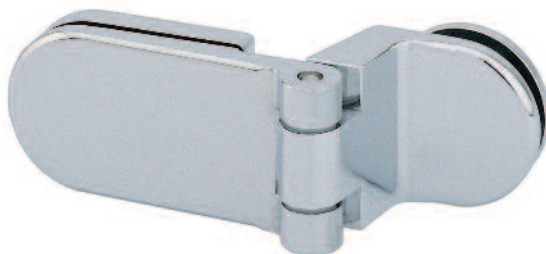

**Références / References**



Laiton poli PVD  
Polished brass PVD

3063.05.0



Chromé brillant  
Bright chromium

3063.30.0



Chromé mat  
Matt chromium

3063.31.0



Effet Inox  
Stainless steel effect

3063.35.0

Charnière à recouvrement,  
simple action  
*Overlapping shower hinge glass  
to glass, one way opening*



Charnières pour  
pare douches  
*Hinges for  
shower screens*



Charnières pour  
pare douches  
*Hinges for  
shower screens*

# Coralia SQ

## Caractéristiques techniques

- Poids maxi par porte 25 kg
- Pour verre trempé de 6 et 8 mm (non fourni)
- Montage sur trous
- Ouverture à 90°
- Livrée avec vis de fixation et intercalaires
- Unité de vente : 1 charnière, conditionnée par 2

## Technical features

- Maximum weight per door 25 kg
- For 6 and 8 mm thick toughened glass (not supplied)
- Assembled onto holes
- Opening through 90°
- Supplied with screws and spacers
- Sold per unit packed in pairs

3069.\*\*.0SQ

## Caractéristiques techniques

- Montage sur encoche 3069E
- Utilisation avec joints bourrelets et joints magnétiques

## Technical features

- For notch 3069E
- Used with compressible profile and magnetic sealing strips

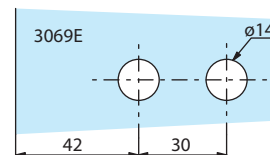
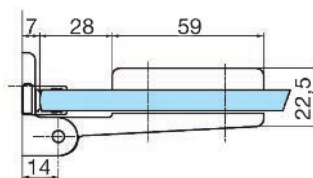
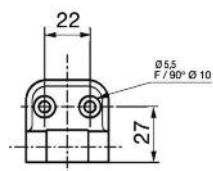
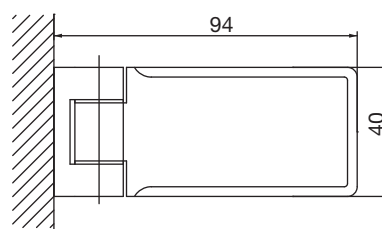

## LES + PRODUITS

*The + product*

Design

Certifié TUV

Design

TUV certified

## Références / References

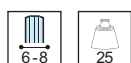

Charnière simple action à 2 trous de fixation  
*Single hinge with 2 fixing points, without blocking point*



Chromé brillant  
*Bright chromium*



Effet Inox  
*Stainless steel effect*

3069.30.0SQ

3069.35.0SQ



## 3062.\*\*.0SQ

### Caractéristiques techniques

- Montage sur encoche 3062E180 pour 2 volumes à 180°
- Montage sur encoche 3062E135 pour 2 volumes à 135°
- Utilisation avec joints bourrelets et joints magnétiques

### Technical features

- 180° blocking point 2 glass panels see notch 3062E180
- 135° blocking point 2 glass panels see notch 3062E135
- Used with compressible profile and magnetic sealing strips

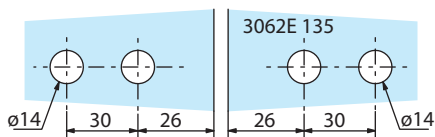
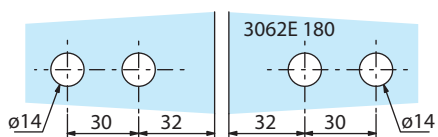
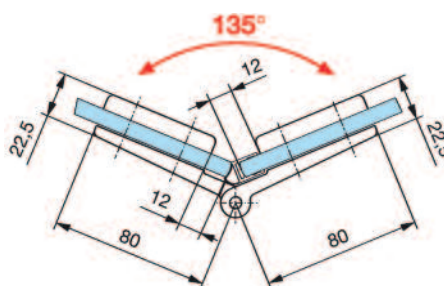
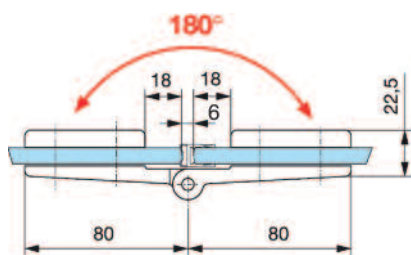
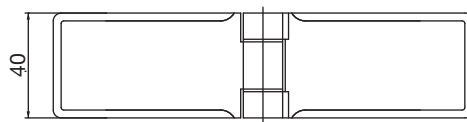

### Références / References



Chromé brillant  
Bright chromium



Effet Inox  
Stainless steel effect

Charnière double, simple action  
*Glass to glass shower hinge, one way opening*

3062.30.0SQ

3062.35.0SQ

Tableau  
de synthèses pour  
charnières  
de douche  
*Technical feature  
table for shower  
hinges*



Marine

Marine SQ

Carréa

Maréva

Mélora

**Esthétique / Design**

Forme rectangulaire horizontale <i>Rectangular horizontal shape</i>	●	●			
Forme arrondie horizontale <i>Rounded horizontal shape</i>				●	
Forme rectangulaire verticale <i>Rectangular vertical shape</i>					●
Formes carrée ou spécifique <i>Square or specific shapes</i>			●		
Accessoires assortis (boutons, barre, pièces fixations) <i>Matching accessories (knobs, bars, partition clips)</i>	●	●	●	●	●

**Fonctions / Functions**

Charnière simple <i>Glass to wall hinge</i>	●	●	●	●	●
Charnière double à 135° <i>Glass to glass hinge at 135°</i>	●			●	●
Charnière double à 180° <i>Glass to glass hinge at 180°</i>	●	●	●	●	●
Charnière double à recouvrement <i>Glass to glass hinge overlapping</i>				●	
Charnière double d'angle <i>Glass to glass hinge corner</i>	●			●	

**Finitions / Finish**

Chromé-Brillant / <i>Bright chromium</i>	●	●	●	●	●
Chromé-Mat / <i>Matt chromium</i>	●	●	●	●	●
Effet inox / <i>Stainless steel effect</i>	●			●	●
Laqué Blanc 9010 <i>Lacquered RAL 9010</i>	●			●	
PVD / PVD	●			●	●

**Fonctionnalités / Features**

Système d'indexage <i>Indexing system</i>	●	●	●	●	●
Système levant / <i>Rising system</i>					
Système anti bruit breveté <i>Anti noise patented system</i>	●	●	●	●	●
Réglage d'angle / <i>Angle adjustment</i>	●	●	●	●	●
Réglage platine de fixation <i>Fixing plate adjustment</i>					
Fonction va-et-vient / <i>Swing function</i>	●	●	●	●	●

**Technique / Technical characteristic**

Compatible joint sur hauteur de porte <i>Possibility to fit seal on the length of door</i>					
Poids maxi / volume verrier <i>Maximum weight / glass panel</i>	60 kg	60 kg	45 kg	40 kg	60 kg
Épaisseur verre / <i>Thickness of glass</i>	8-10 mm	8-10 mm	8-10 mm	6-8 mm	8-10-12 mm
Encoche à trous / <i>Hole shaped notches</i>					
Encoche ouvertes / <i>Open notches</i>	●	●	●	●	●

Tableau de synthèses pour charnières de douche  
*Technical feature table for shower hinges*



Mélora SQ

Kubika

Coralia

Coralia SQ

			●
		●	
●	●		
●	●	●	●
●	●	●	●
●	●	●	●
		●	
●	●	●	●
●	●	●	●
●	●	●	●
●		●	
●	●		
●	●		
●	●		
●			
	●	●	●
60 kg	45 kg	25 kg	25 kg
8-10-12 mm	8-10 mm	6-8 mm	6-8 mm
	●	●	●
●			

Pièces de fixation pour volumes fixes de douches  
*Partition clips for fixed shower screens*

3265.\*\*.0

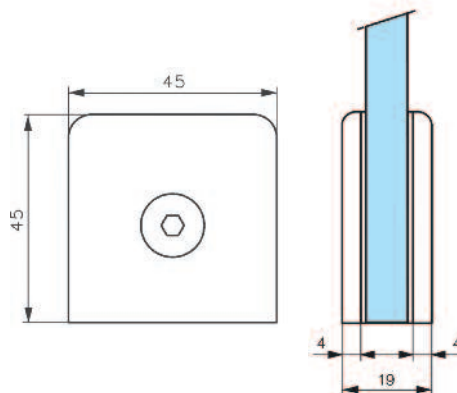
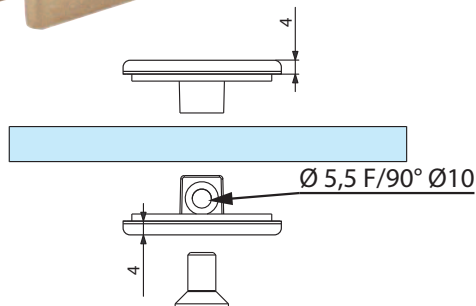
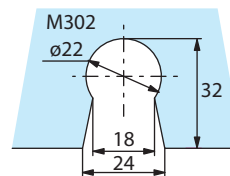

**LES + PRODUITS**

*The + product*

3565 :  
 installation sur muret

3565 :  
 For installation on low wall

Références / References



Laiton poli PVD  
 Polished brass PVD



Chromé brillant  
 Bright chromium



Chromé mat  
 Matt chromium



Effet inox  
 Stainless steel effect



Laqué Blanc 9010  
 Lacquered white RAL9010

Pièce de fixation pour volume fixe  
*Partition clip for fixed panel*

3265.05.0

3265.30.0

3265.31.0

3265.35.0

3265.51.0

3265.\*\*.0SQ

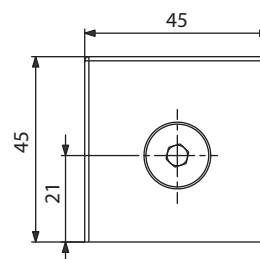
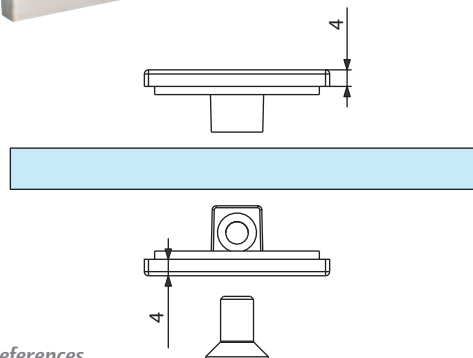
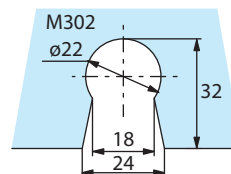

Références / References



Chromé brillant  
 Bright chromium



Chromé mat  
 Matt chromium



Effet inox  
 Stainless steel effect

Pièce de fixation pour volume fixe  
*Partition clip for fixed panel*

3265.30.0SQ

3265.31.0SQ

3265.35.0SQ

3465.\*\*.0

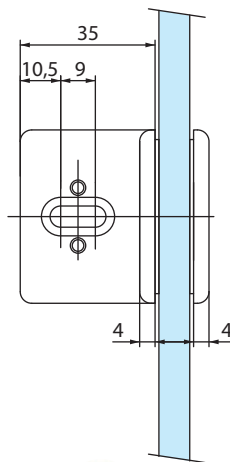
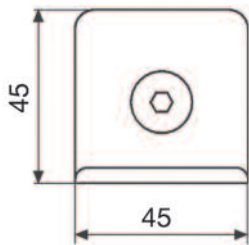
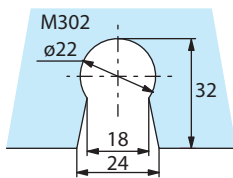

Pièces de fixation  
pour volumes fixes  
de douches  
*Partition clips  
for fixed shower  
screens*

Références / References



Laiton poli PVD Polished brass PVD	Chromé brillant Bright chromium	Chromé mat Matt chromium	Effet inox Stainless steel effect	Laqué Blanc 9010 Lacquered white RAL 9010

Pièce de fixation avec équerre  
pour volume fixe  
*Partition clip for fixed panel*

3465.05.0	3465.30.0	3465.31.0	3465.35.0	3465.51.0
-----------	-----------	-----------	-----------	-----------

3565.\*\*.0

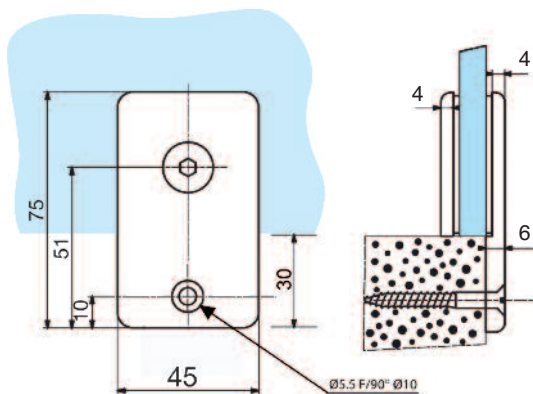
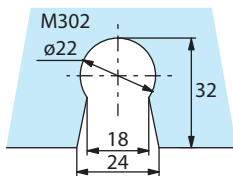

Références / References



Laiton poli PVD Polished brass PVD	Chromé brillant Bright chromium	Chromé mat Matt chromium	Effet inox Stainless steel effect	Laqué Blanc 9010 Lacquered white RAL 9010

Pièce de fixation pour volume fixe  
sur muret  
*Partition clip for fixed panel assembly  
onto low wall*

3565.05.0	3565.30.0	3565.31.0	3565.35.0	3565.51.0
-----------	-----------	-----------	-----------	-----------



Pièces de fixation pour volumes fixes de douches  
*Partition clips for fixed shower screens*

3165.\*\*.0

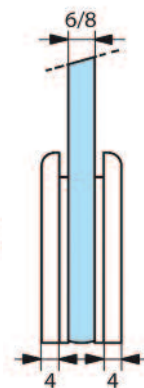
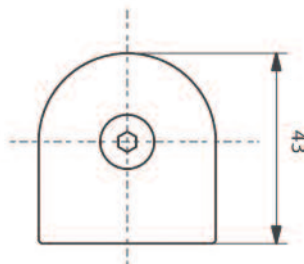
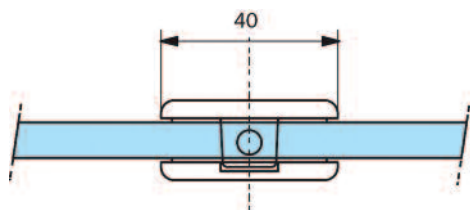
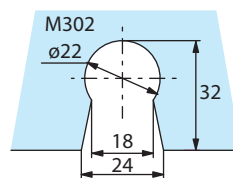

Références / References



Laiton poli PVD  
 Polished brass PVD



Chromé brillant  
 Bright chromium



Chromé mat  
 Matt chromium



Effet inox  
 Stainless steel effect



Laqué Blanc 9010  
 Lacquered white RAL 9010

Pièce de fixation pour volume fixe  
*Partition clip for fixed panel*

3165.05.0

3165.30.0

3165.31.0

3165.35.0

3165.51.0

3085.\*\*.0

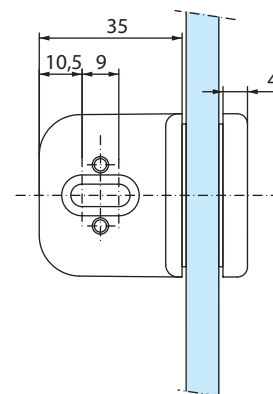
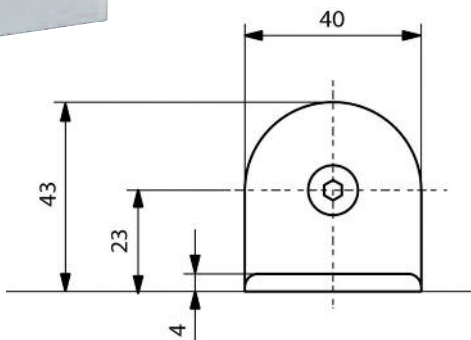
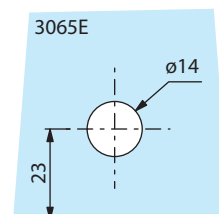
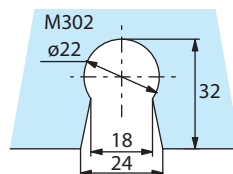

Références / References



Laiton poli PVD  
 Polished brass PVD



Chromé brillant  
 Bright chromium



Chromé mat  
 Matt chromium



Effet inox  
 Stainless steel effect



Laqué Blanc 9010  
 Lacquered white RAL 9010

Pièce de fixation avec équerre pour volume fixe  
*Partition clip for fixed panel*

3085.05.0

3085.30.0

3085.31.0

3085.35.0

3085.51.0

3065.\*\*.0

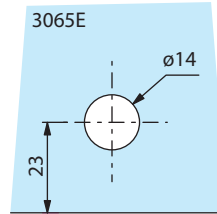

Pièces de fixation pour volumes fixes de douches  
Partition clips for fixed shower screens

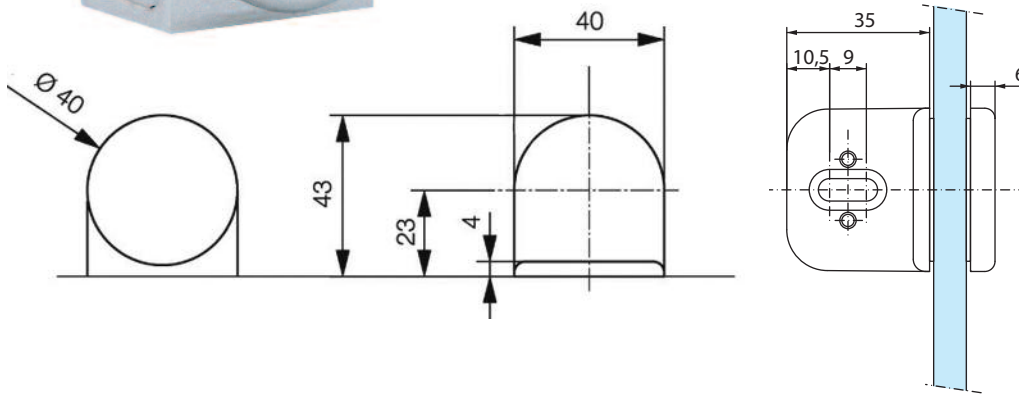

Références / References



Pièce de fixation avec équerre pour volume fixe  
Partition clip for fixed panel

3065.30.0      3065.31.0      3065.35.0

3056.\*\*.0

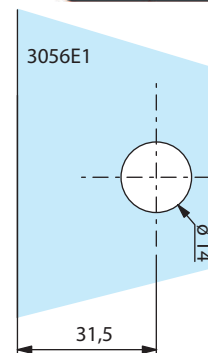
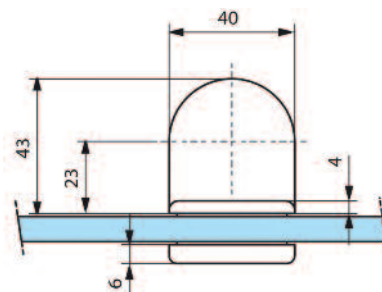
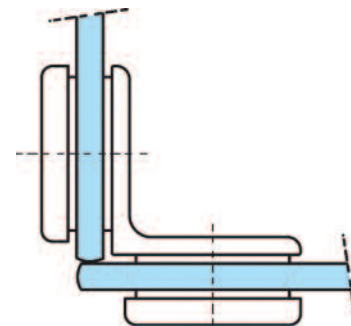
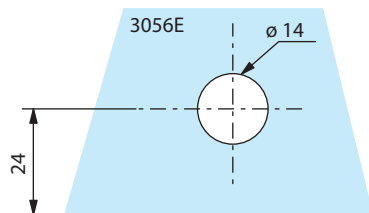

Références / References



Pièce de liaison d'angle pour 2 volumes fixes à 90°  
Corner partition clip for fixed panels at 90°

3056.30.0      3056.31.0      3056.35.0

- Pose au milieu de volume
- Montage sur encoches 3056E et 3056E1

- Assembled in the middle of the panel
- To be assembled on notches 3056E and 3056E1

Pièces de fixation pour volumes fixes de douches  
*Partition clips for fixed shower screens*

3255.\*\*.0

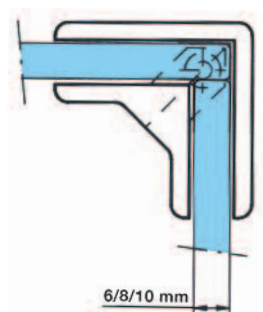
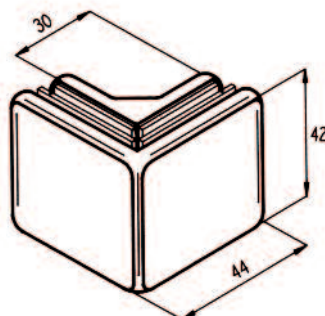
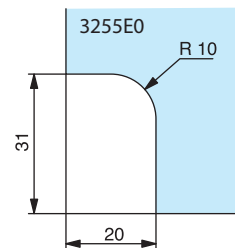

Références / References



Laiton poli PVD  
 Polished brass PVD



Chromé brillant  
 Bright chromium



Chromé mat  
 Matt chromium

Pièce de fixation haute ou basse pour 2 volumes fixes à 90°  
*Corner partition clip for fixed panels at 90°*

3255.05.0

3255.30.0

3255.31.0

- Pose aux extrémités du volume
- Montage sur encoches 3255E0

- Assembled at the edge of the glass
- To be assembled on notches 3255E0

3256.\*\*.0

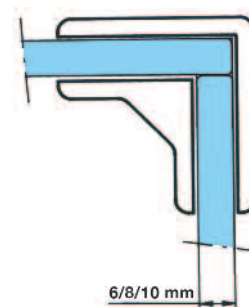
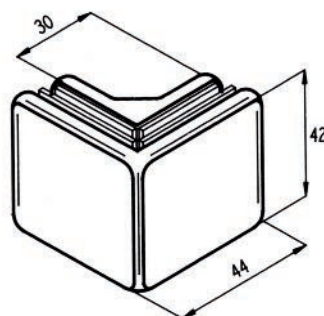
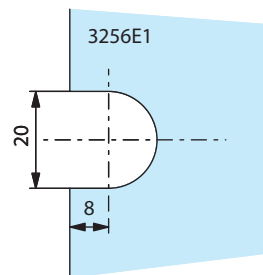
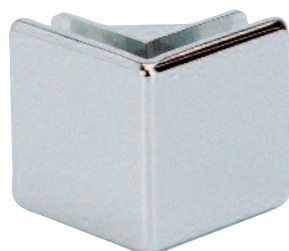

Références / References



Laiton poli PVD  
 Polished brass PVD



Chromé brillant  
 Bright chromium



Chromé mat  
 Matt chromium



Effet inox  
 Stainless steel effect



Laqué Blanc 9010  
 Lacquered white RAL 9010

Pièce de liaison d'angle pour 2 volumes fixes à 90°  
*Corner partition clip for fixed panels at 90°*

3256.05.0

3256.30.0

3256.31.0

3256.35.0

3256.51.0

- Pose au milieu de volume
- Montage sur encoches 3256E1

- Assembled in the middle of the panel
- To be assembled on notches 3256E1

# 3257.\*\*.0

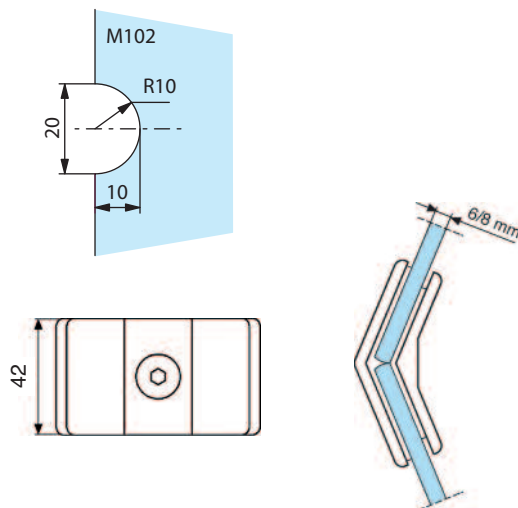

Pièces de fixation pour volumes fixes de douches  
Partition clips for fixed shower screens

## Références / References



Laiton poli PVD  
Polished brass PVD



Chromé brillant  
Bright chromium



Chromé mat  
Matt chromium



Effet inox  
Stainless steel effect

Pièce de liaison d'angle pour 2 volumes fixes à 135°  
Corner partition clip for fixed panels at 135°

3257.05.0

3257.30.0

3257.31.0

3257.35.0

- Pose au milieu de volume
- Montage sur encoches M102

- Assembled in the middle of the panel
- To be assembled on notches M102

# 3258.\*\*.0

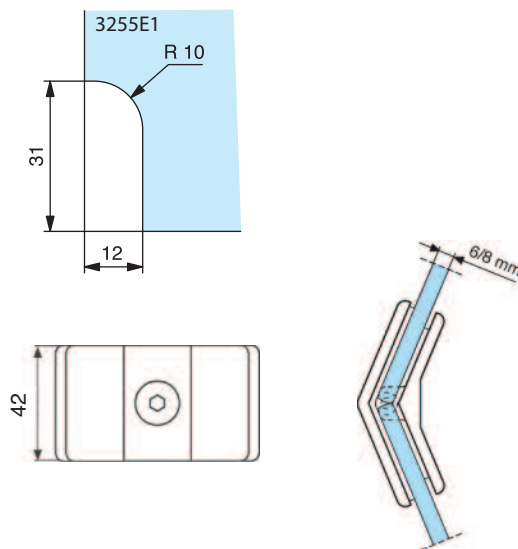

## Références / References



Laiton poli PVD  
Polished brass PVD



Chromé brillant  
Bright chromium



Chromé mat  
Matt chromium

Pièce de fixation haute ou basse pour 2 volumes fixes à 135°  
Corner partition clip for fixed panels at 135°

3258.05.0

3258.30.0

3258.31.0

- Pose aux extrémités du volume
- Montage sur encoches 3255E1

- Assembled at the edge of the glass
- To be assembled on notches 3255E1

## Profils de compensation Correcting profiles

### Caractéristiques techniques générales

- Pour verre trempé de 6 ou 8 mm (suivant les références)
- Montage sans encoche
- Livrée avec joint pour les réf 2818 et 2817
- Unité de vente : 1 profil

### General technical features

- For toughened glass doors 6 or 8 mm
- No notch required
- Supplied with spacers for series 2818 and 2817
- Sold per unit

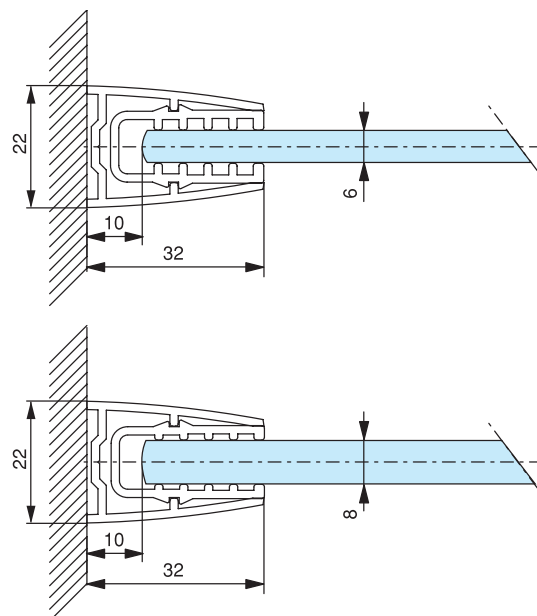
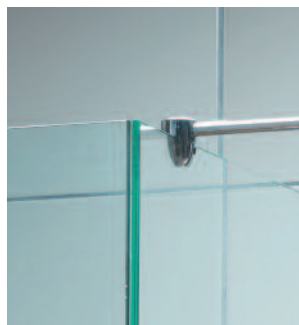

### LES + PRODUITS

The + product

Pose facile

Possibilité de réglage

Étanchéité mur/verre

Easy installation

Possible adjustment

Improved waterproofing wall/glass

### Références / References

Profil de compensation lg 2200 mm pour volume fixe  
Vertical correcting profile length 2200 mm for fixed panel

Alu poli brillant  
Polished aluminium

Chromé mat  
Matt chromium



2818.13.2

2818.31.2



2818.13.3

2818.31.3

- Fixation du profil par vis TF Ø 4 mm (non fourni)
- Compatibilité avec profil pour receveur série 2819

- Profile assembled with screws TF Ø 4 mm (not supplied)
- Compatible with the profile for shower tray series 2819



2819.\*\*\*

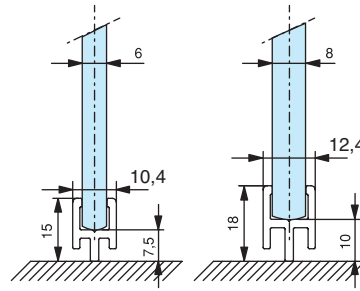

Profils  
de compensation  
Correcting  
profiles

Références / References

Profil bas lg 2200 mm pour volume fixe  
Bottom profile length 2200 mm for fixed panel



Alu poli brillant  
Polished aluminium



Chromé mat  
Matt chromium



2819.13.2

2819.31.2



2819.13.3

2819.31.3

- Profil à clipper sur le verre
- Fixation du profil sur le receveur par 2 joints silicone de chaque côté de la barrette centrale
- Compatible avec profil de compensation série 2818

- Profile clipped onto glass
- Profile fixed onto the tray by 2 silicone seals on each side of central rail
- Compatible with correcting profile series 2818

EM2819.\*\*.3



Chromé brillant  
Bright chromium



Chromé mat  
Matt chromium

Références / References

10 Embouts de profil pour 2819.xx.3  
10 covers for profile 2819.xx.3

EM2819.30.3

EM2819.31.3

Barres raidisseurs  
pour volumes fixes  
Reinforcement bars  
for fixed panels

# Profil raidisseur sol plafond pour paroi fixe

## Floor to ceiling support for fixed shower screen



- Obturateur pour la rainure du tube entre le haut du verre et le plafond.
- Fixation au plafond et au sol par vis invisible.
- Montage du verre dans le tube avec joint PVC - Pour Verre trempé ép: 8mm
- Compatible avec le profil bas réf 2819.13.3
- Possibilité d'utilisation avec verre ép 6mm (Joint + silicone)
- Possibilité d'utilisation avec verre ép 10mm (Sans joint uniquement silicone)
- Disponible en Kit de fixation intégrale (réf 2816+2819+2818)

- Shutter for the opening in the tube between ceiling and glass
- Invisible fixing point on the floor and ceiling
- Installation of the glass with PVC jointing strip for 8mm tempered glass.
- Compatible with bottom profile 2819.13.3
- Can be used with 6mm glass (plastic profile +silicone)
- Can be used with 10mm glass (only silicone no plastic profile)
- Available in full fixing kit (ref 2816+2819/2818)

### LES + PRODUITS

The + product

Haute résistance à la corrosion (ISO 0227-2007)

Pour volume de grande hauteur

Montage sans encoche.

Solution esthétique de fixation de volume fixe.

Solution KIT de fixation intégrale WPROF02

Without glass cutting.

High corrosion resistance (ISO 0227-2007)

For high glass panels

Aesthetic solution for fixed panel.

Available in full fixing kit WPROF02

### Caractéristiques techniques

- Pour verre de 8 mm
- Sans encoche
- Design tube Ø 34mm pour une meilleur rigidité
- Longueur 3000 mm ajustable par recoupe
- Recouvrement de la coupe pour une finition parfaite
- Fixation par 2 vis
- Pose sans silicone
- Hauteur maxi du verre = 2200mm

### Technical features

- For 8mm thick toughened glass
- No notch needed
- Design round Ø34mm
- Length of the profile 3000mm can be shortened
- Fixing by 2 screws
- Installation with joint no silicone
- Covering of the cut for a perfect finish
- Max. height of the glass = 2200mm

## 2816.13.3

### Références / References



Profil raidisseur sol plafond pour paroi fixe  
Floor to ceiling support for fixed shower panels



Alu poli brillant  
Polished aluminium

2816.13.3

### Kits complets / Complete kits

Kit fixation intégrale comprenant 2816 + 2819 + 2818  
Full fixing kit composed of 2816+2819+2818

WPROF02/03.13

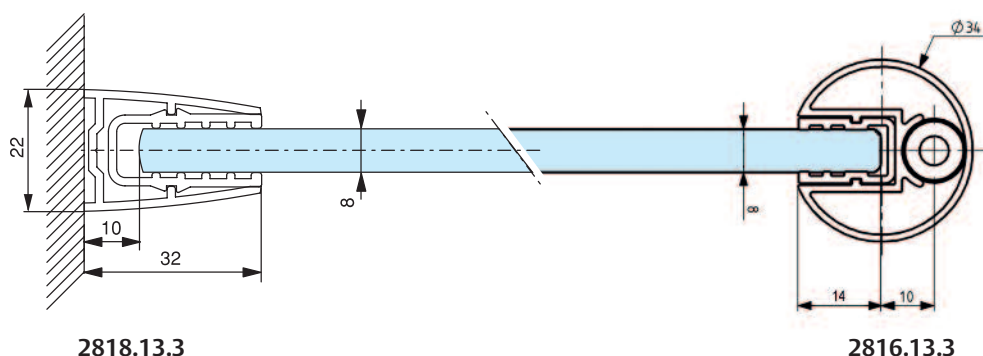

Barres raidisseurs  
pour volumes fixes  
*Reinforcement bars  
for fixed panels*





## LES + PRODUITS

The + product

Pas d'encoche

No notch

## Profils U et L décor alu poli brillant

U and L profiles Polished aluminium finish



Alu poli brillant  
Polished aluminium

### Références / References

Profil U 15x15x15x2 mm largeur intérieure 11 mm longueur de 3000 mm <i>U-profile 15x15x15x2 mm 11 mm inside width 3000 mm length</i>	<b>U151515.13</b>
Profil U 20x12x20x1,5 mm largeur intérieure 9 mm longueur de 3000 mm <i>U-profile 20x12x20x1,5 mm 9 mm inside width 3000 mm length</i>	<b>U201220.13</b>
Profil U 20x15x20x2 mm largeur intérieure 11 mm longueur de 3000 mm <i>U-profile 20x15x20x2 mm 11 mm inside width 3000 mm length</i>	<b>U201520.13</b>
Profil U 20x17x20x2 mm largeur intérieure 13 mm longueur de 3000 mm <i>U-profile 20x17x20x2 mm 13 mm inside width 3000 mm length</i>	<b>U201720.13</b>
Profil U 20x20x20x2 mm largeur intérieure 16 mm longueur de 3000 mm <i>U-profile 20x20x20x2 mm 16 mm inside width 3000 mm length</i>	<b>U202020.13</b>
Profil U 30x20x30x2 mm largeur intérieure 16 mm longueur de 3000 mm <i>U-profile 30x20x30x2 mm 16 mm inside width 3000 mm length</i>	<b>U302030.13</b>
Profil U 40x20x40x2 mm largeur intérieure 16 mm longueur de 3000 mm <i>U-profile 40x20x40x2 mm 16 mm inside width 3000 mm length</i>	<b>U402040.13</b>
Profil L 15x15x2 mm longueur de 3000 mm <i>L-profile 15x15x2 mm 3000 mm length</i>	<b>L1515.13</b>
Profil L 20x20x2 mm longueur de 3000 mm <i>L-profile 20x20x2 mm 3000 mm length</i>	<b>L2020.13</b>
Profil L 25x25x2 mm longueur de 3000mm <i>L-profile 25x25x2 mm 3000 mm length</i>	<b>L2525.13</b>

**Quantités minimum de commande par référence = 5 longueurs**

**Quantités de lots par référence = 5 longueurs**

*Minimum quantity per order and per reference = 5 lengths*

*Sold in packs per reference = 5 lengths*



1651.\*\*.0

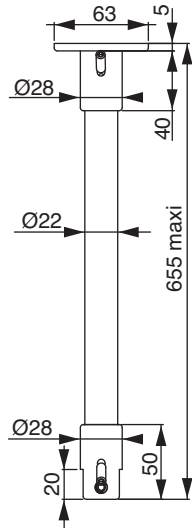
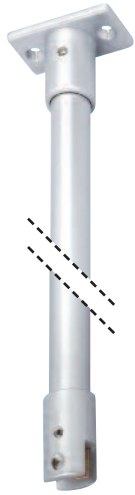

Barres raidisseurs  
pour volumes fixes  
Reinforcement bars  
for fixed panels

Références / References



Barre raidisseur verre/plafond lg : 635 mm  
Reinforcement bar for shower glass/ceiling  
635 mm length



Chromé brillant  
Bright chromium

1651.30.0



Chromé mat  
Matt chromium

1651.31.0



Effet inox  
Stainless steel effect

1651.35.0

- Maintien des volumes fixes par pinces et serrage par vis à embout
- Tube de longueur 600 mm ajustable par recoupe

- Fixed panel is held in place by a clip tightened by a plastic tipped screw
- 600 mm length tube modified by cutting down to required size

1657.\*\*.0

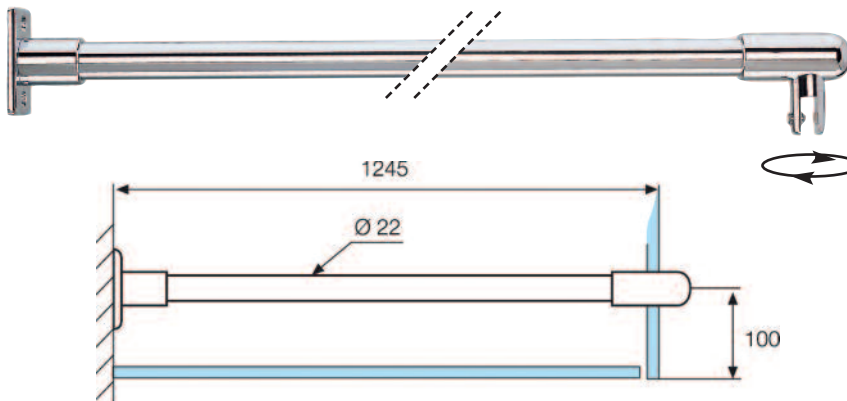

Références / References



Barre raidisseur mur/verre lg 1200 mm  
Reinforcement bar for shower glass/wall  
1200 mm length



Laiton poli PVD  
Polished brass PVD

1657.05.0



Chromé brillant  
Bright chromium

1657.30.0



Chromé mat  
Matt chromium

1657.31.0



Effet inox  
Stainless steel effect

1657.35.0



Laqué blanc 9010  
Lacquered white RAL 9010

1657.51.0

- Maintien du volume fixe par pince orientable et serrage par vis à embout
- Tube de longueur 1200 mm ajustable par recoupe
- Montage possible sans la platine

- Fixed panel is held in place by an adjustable clip tightened by a plastic tipped screw
- 1200 mm length tube modified by cutting down to required size
- Possible installation without the plate

ASSA ABLOY

Barres raidisseurs pour volumes fixes  
Reinforcement bars for fixed panels

1652.\*\*.0

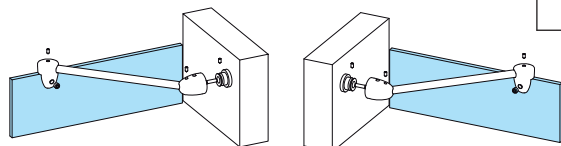
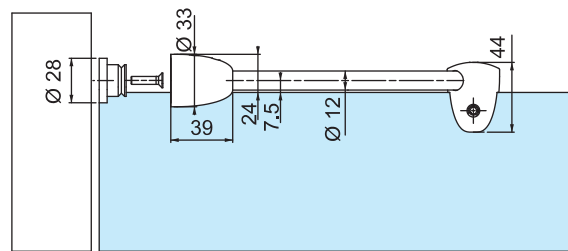
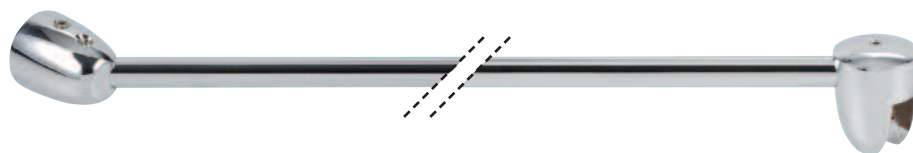

Références / References



Chromé brillant  
Bright chromium



Chromé mat  
Matt chromium

1652.30.0

1652.31.0

Kit 2 barres raidisseurs d'angle droite et gauche  
Kit comprising 2 corner reinforcement bars left and right

- Maintien des volumes fixes par pinces et serrage par vis à embout
- Tube de longueur 500 mm ajustable par recoupe

- Fixed panel is held in place by a clip tightened by a plastic tipped screw
- 500 mm length tube modified by cutting down to required size

LES + PRODUITS

The + product

Ajustable facilement

Gamme complète

Easy adjustment

Complete range

1652.\*\*.0G

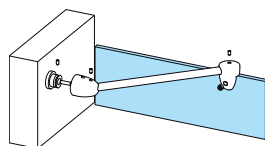

Références / References



Chromé brillant  
Bright chromium



Chromé mat  
Matt chromium



Effet inox  
Stainless steel effect



Laqué blanc 9010  
Lacquered white RAL 9010

1652.30.0G

1652.31.0G

1652.35.0G

1652.51.0G

Barre raidisseur d'angle gauche lg 1000 mm  
Corner reinforcement bar left 1000 mm length

- Maintien des volumes fixes par pinces et serrage par vis à embout
- Tube de longueur 1000 mm ajustable par recoupe

- Fixed panel is held in place by a clip tightened by a plastic tipped screw
- 1000 mm length tube modified by cutting down to required size

1652.\*\*.0D

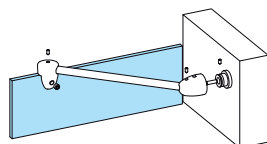

Références / References



Chromé brillant  
Bright chromium



Chromé mat  
Matt chromium



Effet inox  
Stainless steel effect



Laqué blanc 9010  
Lacquered white RAL 9010

1652.30.0D

1652.31.0D

1652.35.0D

1652.51.0D

Barre raidisseur d'angle droite lg 1000 mm  
Corner reinforcement bar right 1000 mm length

- Maintien des volumes fixes par pinces et serrage par vis à embout
- Tube de longueur 1000 mm ajustable par recoupe

- Fixed panel is held in place by a clip tightened by a plastic tipped screw
- 1000 mm length tube modified by cutting down to required size

# 1657.\*\*.1

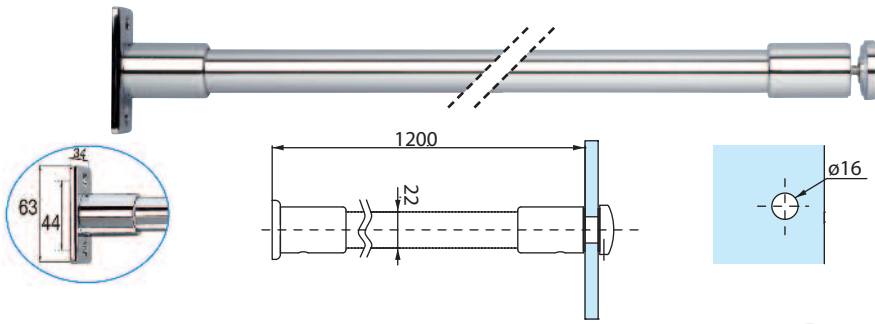

Barres raidisseurs pour volumes fixes  
Reinforcement bars for fixed panels

## Références / References



Barre raidisseur mur/verre lg 1200 mm  
Reinforcement bar for shower glass/wall  
1200 mm length

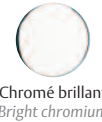

Chromé brillant  
Bright chromium



Chromé mat  
Matt chromium

1657.30.1

1657.31.1

- Montage sur le verre trempé avec 1 trou Ø 16 MM
- Tube de longueur 1200 mm ajustable par recoupe
- Montage possible sans la platine

- Mounting hole Ø 16 mm
- 1200 mm length tube modified by cutting down to required size
- Possible installation without the plate

# 1657.\*\*.2SQ

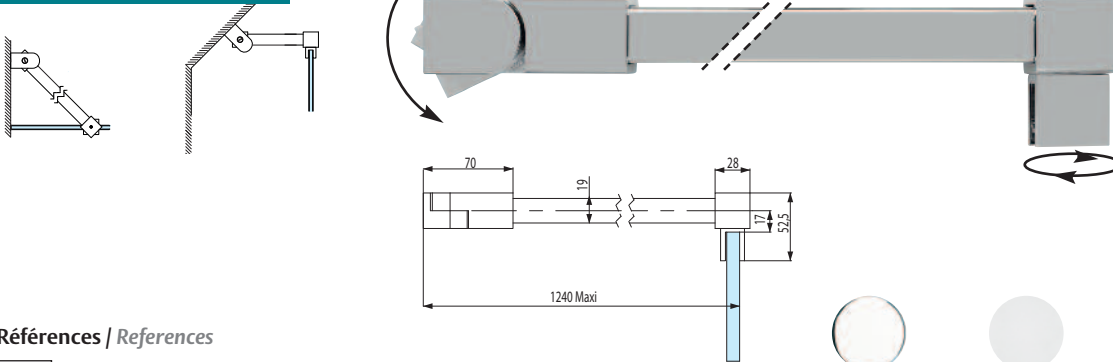

## Références / References



Barre raidisseur carrée articulée mur/verre lg 1200 mm  
Articulated square reinforcement bar for shower glass/wall 1200 mm length



Chromé brillant  
Bright chromium



Chromé mat  
Matt chromium

1657.30.2SQ

1657.31.2SQ

- Possibilité de montage en angle ou sous pente avec la platine de fixation orientable
- Maintien du volume fixe par pince orientable et serrage par vis à embout
- Tube de longueur 1200 mm ajustable par recoupe

- Possibility of assembling in a corner or on an incline with an adjustable fixing plate
- Fixed panel is held in place by an adjustable clip tightened by a plastic tipped screw
- 1200 mm length tube modified by cutting down to required size

# 1657.\*\*.0D12

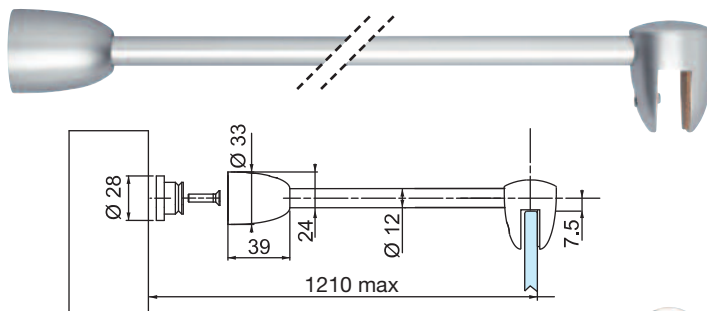

## Références / References



Barre raidisseur mur/verre parallèle lg 1200 mm  
Reinforcement bar for shower glass/wall 1200 mm length



Chromé brillant  
Bright chromium



Chromé mat  
Matt chromium

1657.30.0D12

1657.31.0D12

- Maintien du volume fixe par pince et serrage par vis à embout
- Tube de longueur 1200 mm ajustable par recoupe

- Fixed panel is held in place by a clip tightened by a plastic tipped screw
- 1200 mm length tube modified by cutting down to required size

Barres raidisseurs  
pour volumes fixes  
Reinforcement bars  
for fixed panel

1658.\*\*.0

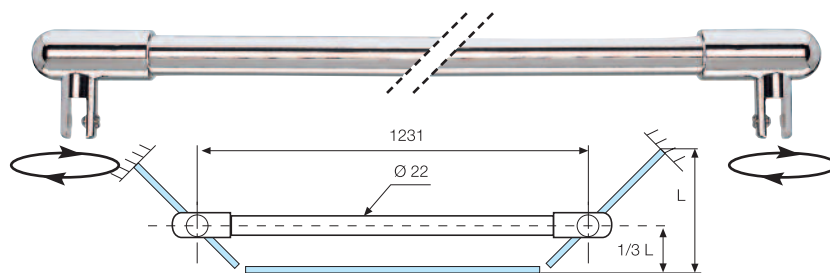

Références / References



Laiton poli PVD  
Polished brass PVD



Chromé brillant  
Bright chromium



Chromé mat  
Matt chromium



Effet inox  
Stainless steel effect



Laqué blanc 9010  
Lacquered white RAL 9010

Barre raidisseur verre/verre lg 1200 mm  
Reinforcement bar for shower glass/glass  
1200 mm length

1658.05.0

1658.30.0

1658.31.0

1658.35.0

1658.51.0

- Maintien du volume fixe par pince orientable et serrage par vis à embout
- Tube de longueur 1200 mm ajustable par recoupe
- Fixed panel is held in place by an adjustable clip tightened by a plastic tipped screw
- 1200 mm length tube modified by cutting down to required size

1658.\*\*.2SQ

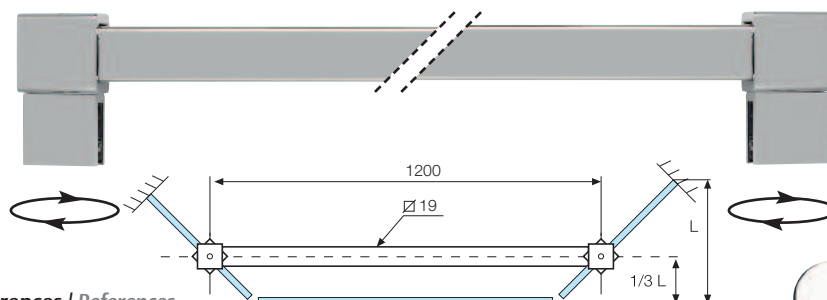

Références / References



Chromé brillant  
Bright chromium



Chromé mat  
Matt chromium

Barre raidisseur carrée verre/verre lg 1200 mm  
Articulated square reinforcement bar for shower glass/glass 1200 mm length

1658.30.2SQ

1658.31.2SQ

- Maintien du volume fixe par pince orientable et serrage par vis à embout
- Tube de longueur 1200 mm ajustable par recoupe
- Fixed panel is held in place by an adjustable clip tightened by a plastic tipped screw
- 1200 mm length tube modified by cutting down to required size

1658.\*\*.0D12

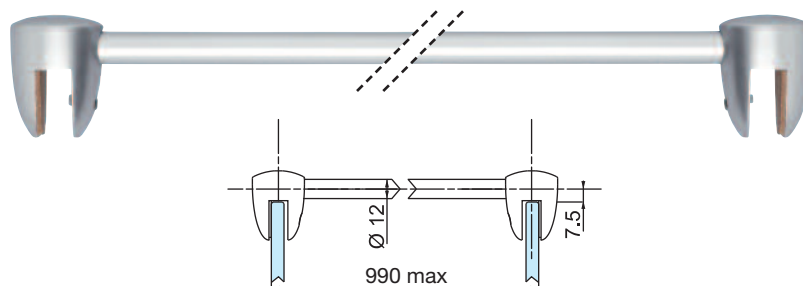

Références / References



Chromé brillant  
Bright chromium



Chromé mat  
Matt chromium

Barre raidisseur verre/verre parallèle lg 1000 mm  
Reinforcement bar for shower glass/glass  
1000 mm length

1658.30.0D12

1658.31.0D12

- Maintien du volume fixe par pince et serrage par vis à embout
- Tube de longueur 1000 mm ajustable par recoupe
- Fixed panel is held in place by a clip tightened by a plastic tipped screw
- 1000 mm length tube modified by cutting down to required size

1658.\*\*.1D12

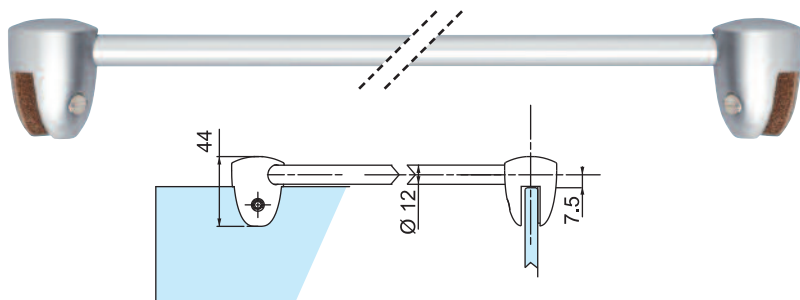

Références / References



Chromé brillant  
Bright chromium



Chromé mat  
Matt chromium

Barre raidisseur d'angle verre/verre lg 1000 mm  
Corner reinforcement bar for shower glass/glass  
1000 mm length

1658.30.1D12 1658.31.1D12

- Maintien du volume fixe par pince et serrage par vis à embout
- Tube de longueur 1000 mm ajustable par recoupe

- Fixed panel is held in place by a clip tightened by a plastic tipped screw
- 1200 mm length tube modified by cutting down to required size

1659.\*\*.0

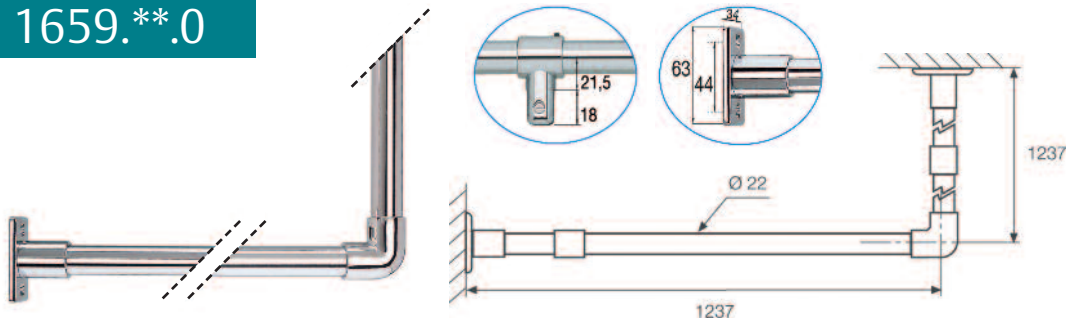

Références / References



Laiton poli PVD  
Polished brass PVD



Chromé brillant  
Bright chromium



Chromé mat  
Matt chromium



Effet inox  
Stainless steel effect

Barre raidisseur d'angle lg 1200 mm  
Corner reinforcement bar 1200 mm length

1659.05.0 1659.30.0 1659.31.0 1659.35.0

- Maintien des volumes fixes par 2 pinces coulissantes et serrage par vis à embout
- 2 tubes de longueur 1200 mm ajustable par recoupe

- Fixed panel is held in place by 2 sliding clips tightened by a plastic tipped screw
- 2 tubes 1200 mm length modified by cutting down to required size

1668.\*\*.0

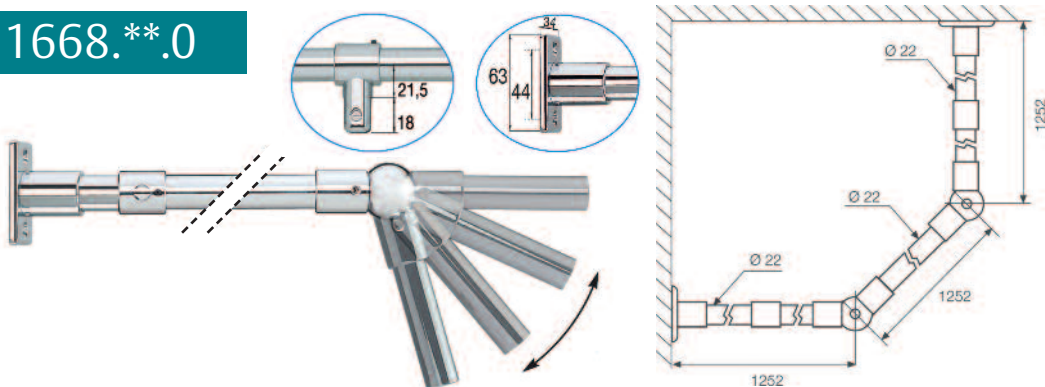

Références / References



Laiton poli PVD  
Polished brass PVD



Chromé brillant  
Bright chromium



Chromé mat  
Matt chromium



Effet inox  
Stainless steel effect

Barre raidisseur 3 volumes à angle réglable  
Reinforcement bar 3 panels with adjustable angle

1668.05.0 1668.30.0 1668.31.0 1668.35.0

- Maintien des volumes fixes par 2 pinces coulissantes et serrage par vis à embout
- 3 tubes de longueur 1200 mm ajustable par recoupe

- Fixed panel is held in place by 2 sliding clips tightened by a plastic tipped screw
- 3 tubes 1200 mm length modified by cutting down to required size



Barres raidisseurs  
pour volumes fixes  
Reinforcement bars  
for fixed panels

1669.\*\*.0

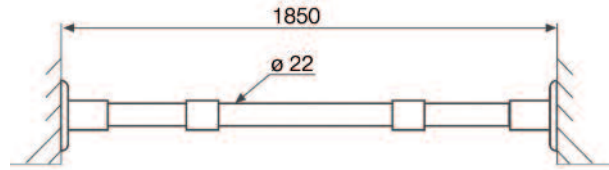
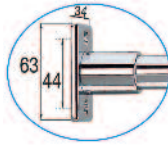
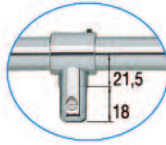
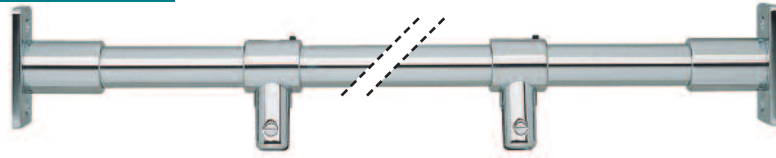

Références / References



Laiton poli PVD  
Polished brass PVD



Chromé brillant  
Bright chromium



Chromé mat  
Matt chromium



Effet inox  
Stainless steel effect

Barre raidisseur mur/mur  
Reinforcement bar wall/wall

1669.05.0

1669.30.0

1669.31.0

1669.35.0

- Maintien des volumes fixes par 2 pinces coulissantes et serrage par vis à embout
- Tube de longueur 1800 mm ajustable par recoupe et 2400 mm en finition 05

- Fixed panel is held in place by 2 sliding clips tightened by a plastic tipped screw
- 1800 mm length tube modified by cutting down to required size and 2400 mm for finish 05

1669.\*\*.2SQ

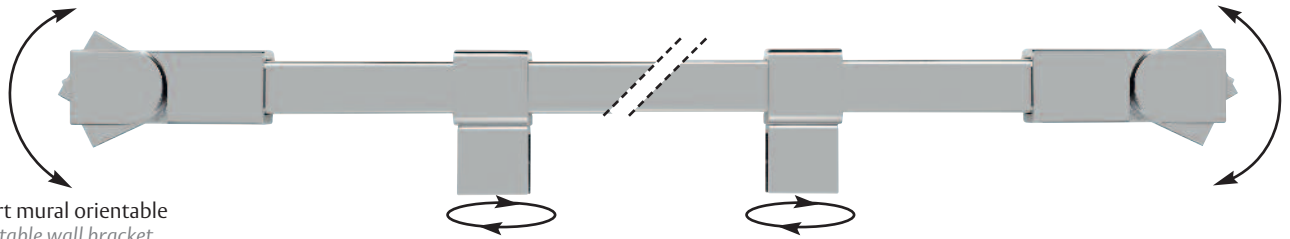

Support mural orientable  
Adjustable wall bracket

Pince orientable  
Adjustable clip

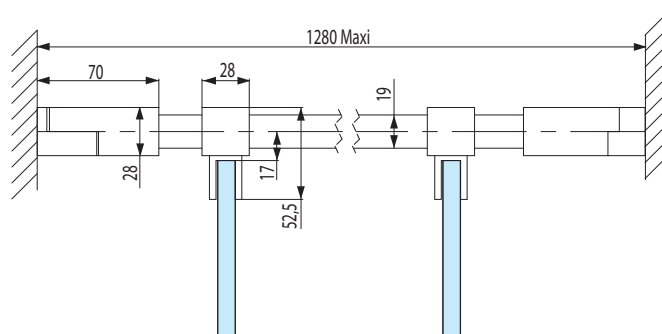

Références / References



Chromé brillant  
Bright chromium



Chromé mat  
Matt chromium

Barre raidisseur carrée mur/mur lg 1200 mm  
Articulated square reinforcement bar for shower wall/wall 1200 mm length

1669.30.2SQ

1669.31.2SQ

- Possibilité de montage sous pente avec la platine de fixation orientable
- Maintien du volume fixe par pince orientable et serrage par vis à embout
- Tube de longueur 1200 mm ajustable par recoupe

- Possibility of assembling on an incline with an adjustable fixing plate
- Fixed panel is held in place by an adjustable clip tightened by a plastic tipped screw
- 1200 mm length tube modified by cutting down to required size

# S110.\*\*.0



## Références / References



Chromé brillant  
Bright chromium



Chromé mat  
Matt chromium



Effet inox  
Stainless steel effect

Taquet de fixation pour barre série 1651  
Bracket for bar series 1651

S110.30.0

S110.31.0

S110.35.0

- Pour tube Ø 22 mm
- Maintien du volume fixe par pince orientable et serrage par vis à embout

- For Ø 22 mm tube
- Fixed panel is held in place by an adjustable clip tightened by a plastic tipped screw

# S120.\*\*.0



## Références / References



Laiton poli PVD  
Polished brass PVD



Chromé brillant  
Bright chromium



Chromé mat  
Matt chromium



Effet inox  
Stainless steel effect



Laqué blanc 9010  
Lacquered white RAL 9010

Pièce de fixation murale pour barres séries 1651/57/59/68/69  
Wall fixing plate for bars series 1651/57/59/68/69

S120.05.0

S120.30.0

S120.31.0

S120.35.0

S120.51.0

- Pour tube Ø 22 mm
- For Ø 22 mm tube

# S130.\*\*.0



## Références / References



Chromé brillant  
Bright chromium



Chromé mat  
Matt chromium



Effet inox  
Stainless steel effect

Taquet avec coulisse pour barres séries 1659/68/69  
Sliding bracket for bars series 1659/68/69

S130.30.0

S130.31.0

S130.35.0

- Pour tube Ø 22 mm
- Maintien du volume fixe par pince coulissante et serrage par vis à embout

- For Ø 22 mm tube
- Fixed panel is held in place by a sliding clip tightened by a plastic tipped screw

# S140.\*\*.0



## Références / References



Chromé brillant  
Bright chromium



Chromé mat  
Matt chromium



Effet inox  
Stainless steel effect



Laqué blanc 9010  
Lacquered white RAL 9010

Embout avec taquet pour barre série 1657/1658  
End cap for bars series 1657/1658

S140.30.0

S140.31.0

S140.35.0

S140.51.0

- Pour tube Ø 22 mm
- Maintien du volume fixe par pince orientable et serrage par vis à embout

- For Ø 22 mm tube
- Fixed panel is held in place by an adjustable clip tightened by a plastic tipped screw

Accessoires pour  
barre raidisseur  
Ø 22 mm  
Accessories for  
reinforcement bar  
Ø 22 mm

Accessoires pour  
barre raidisseur  
Ø 22 mm  
Accessories for  
reinforcement bar  
Ø 22 mm

S150.\*\*.0

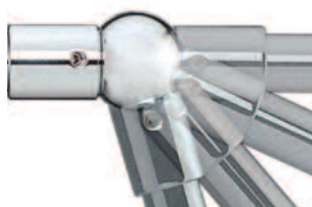

Références / References

Coude réglable pour TUBE Ø 22 mm  
Adjustable bend for Ø 22 mm tube



Chromé brillant  
Bright chromium



Chromé mat  
Matt chromium

S150.30.0

S150.31.0

S151.\*\*.0



Références / References

 Pièce de raccord pour tube Ø 22 mm  
 Connector for Ø 22 mm tube



Chromé brillant  
Bright chromium



Chromé mat  
Matt chromium

S151.30.0

S151.31.0

• Maintien du volume fixe par pince orientable et serrage par vis à embout • Fixed panel is held in place by an adjustable clip tightened by a plastic tipped screw

S152.\*\*.0



Références / References

Raccordement en T  
T - Connector for reinforcement bars



Chromé brillant  
Bright chromium



Chromé mat  
Matt chromium



Effet inox  
Stainless steel effect

S152.30.0

S152.31.0

S152.35.0

• Pour tube Ø 22 mm • For Ø 22 mm tube

S154.\*\*.0



Références / References

Pièce de liaison pour 2 tubes  
Connector for 2 tubes



Laiton poli PVD  
Polished brass PVD

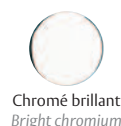

Chromé brillant  
Bright chromium



Chromé mat  
Matt chromium

S154.05.0

S154.30.0

S154.31.0

• Pour tube Ø 22 mm • For Ø 22 mm tube

Tubes



Références / References

T120.\*\*.0

Tube Ø 22 mm lg 1200 mm  
Tube Ø 22 mm 1200 mm length



Chromé brillant  
Bright chromium



Chromé mat  
Matt chromium

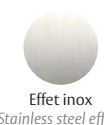

Effet inox  
Stainless steel effect

T120.30.0

T120.31.0

T120.35.0

T180.\*\*.0

Tube Ø 22 mm lg 1800 mm  
Tube Ø 22 mm 1800 mm length

T180.30.0

T180.31.0

T180.35.0

1660.\*\*.0

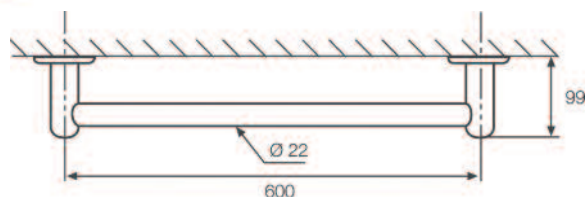

Laiton poli PVD  
Polished brass PVD



Chromé brillant  
Bright chromium



Chromé mat  
Matt chromium

Références / References

Porte serviette simple fixation murale  
Single towel rail for wall

1660.05.0

1660.30.0

1660.31.0

- Fixation sur le mur par platine (visserie fournie)
- Longueur standard du tube 600 mm
- Tube de longueur 600 mm recoupable pour mise à longueur

- Fixed on the wall by plate (screws provided)
- Standard length of tube 600 mm
- Tube 600 mm modified by cutting down lengthwise

Porte serviettes et  
porte tablettes  
Towel rail and  
shelf supports



1661.\*\*.0

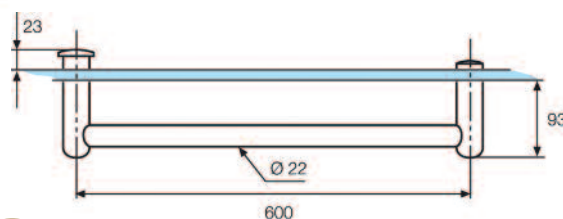
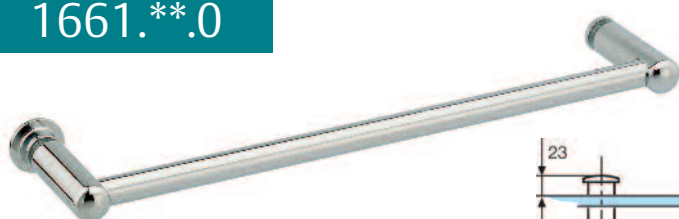

Laiton poli PVD  
Polished brass PVD



Chromé brillant  
Bright chromium



Chromé mat  
Matt chromium



Effet inox  
Stainless steel effect

Références / References



Porte serviette simple fixation verre  
Single towel rail for glass

1661.05.0

1661.30.0

1661.31.0

1661.35.0

- Bouton de manoeuvre intérieur (livré avec 2<sup>ème</sup> écrou de fixation pour utilisation sans bouton intérieur)
- Montage sur trous Ø 16 mm
- Longueur standard du tube 600 mm, entr'axe des trous à 600 mm
- Tube de longueur 600 mm recoupable pour mise à longueur, l'entr'axe des trous de fixation est égal à la longueur du tube

- Knob for manoeuvring on inside (supplied with a second fixing nut to use instead of inside knob)
- To be assembled on 16 mm Ø hole
- Standard length of tube 600 mm, central distance between hole cut-outs 600 mm
- Tube 600 mm modified by cutting down lengthwise, the central distance is equal to the length of the tube

LES + PRODUITS  
The + product

Double fonction :  
tirage et support  
serviette

Esthétique  
compatible avec  
les barres raidisseurs

Double fonction :  
Pulling handle and  
towel rail

Attractive match with  
reinforcement bars

1662.\*\*.0

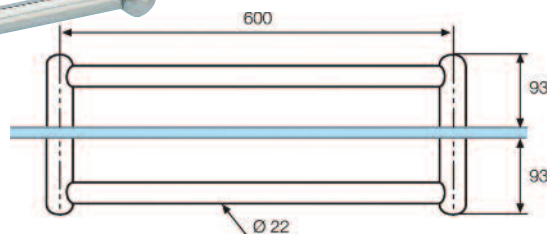

Laiton poli PVD  
Polished brass PVD



Chromé brillant  
Bright chromium



Chromé mat  
Matt chromium



Effet inox  
Stainless steel effect



Porte serviette double fixation verre  
Double towel rail for glass

Références / References

1662.05.0

1662.30.0

1662.31.0

1662.35.0

- Barre de manoeuvre intérieure
- Montage sur trous Ø 16 mm
- Longueur standard du tube 600 mm, entr'axe des trous à 600 mm
- Tube de longueur 600 mm recoupable pour mise à longueur, l'entr'axe des trous de fixation est égal à la longueur du tube

- Bar for manoeuvring on inside
- To be assembled on 16 mm Ø hole
- Standard length of tube 600 mm, central distance between hole cut-outs 600 mm
- Tube 600 mm modified by cutting down lengthwise, the central distance is equal to the length of the tube

Porte serviettes et  
porte tablettes  
Towel rail and  
shelf supports

1664.\*\*.0

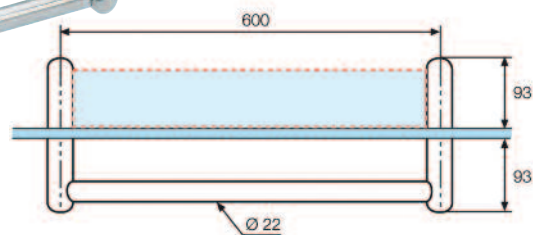
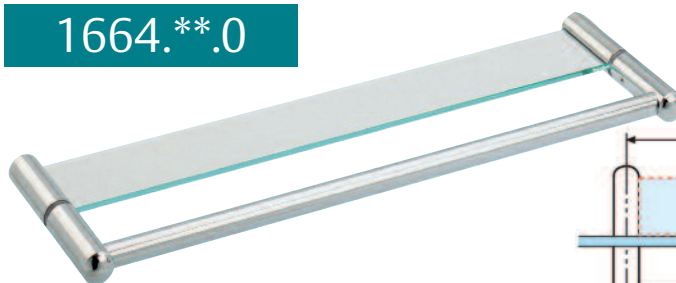

Références / References



Porte serviette avec porte tablette intérieur  
Towel rail with interior shelf



Chromé brillant  
Bright chromium



Chromé mat  
Matt chromium

1664.30.0

1664.31.0

- Porte serviette extérieur
- Porte tablette verre intérieur
- Montage sur trous Ø 16 mm
- Longueur standard du tube porte serviette 600 mm, entr'axe des trous à 600 mm
- Tube recoupable pour mise à longueur, l'entr'axe des trous est égal à la longueur du tube
- Pour tablette en verre épaisseur 6 mm largeur 80 mm (non fournie)
- La longueur de la tablette est égale à l'entr'axe de fixation des supports -16 mm

- Exterior towel rail
- Interior glass shelf support
- Assembling on holes dia 16 mm
- Standard length of towel rail tube 600 mm, central distances between hole cut-outs 600 mm
- Tube modified by cutting down lengthwise, the central distance is equal to the length of tube
- For 6 mm glass shelf 80 mm wide (not supplied)
- The length of the shelf is equal to the support's fixing point -16 mm

Attention : Le verre de la tablette n'est pas fourni

Attention : The glass shelf is not supplied

1665.\*\*.0

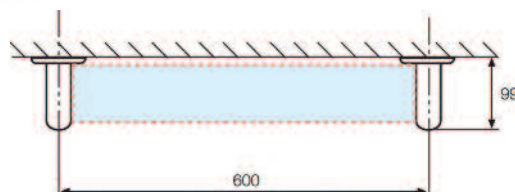

Références / References

Porte tablette fixation murale  
Shelf support for assembling on wall



Chromé brillant  
Bright chromium



Chromé mat  
Matt chromium

1665.30.0

1665.31.0

- Fixation sur le mur par platine (visserie fournie)
- Pour tablette en verre épaisseur 6 mm largeur 80 mm
- La longueur de la tablette est égale à l'entr'axe de fixation des supports -16 mm

- Fixed onto the wall by a plate (screws supplied)
- For 6 mm glass shelf 80 mm wide
- The length of the shelf is equal to the central distance of the support's fixing point -16 mm

Attention : Le verre de la tablette n'est pas fourni

Attention : The glass shelf is not supplied



Porte serviettes et  
porte tablettes  
*Towel rail and  
shelf supports*



Joint pour portes  
et pare douches  
*Sealing strips for  
shower doors and  
screens*

1801.66.\*

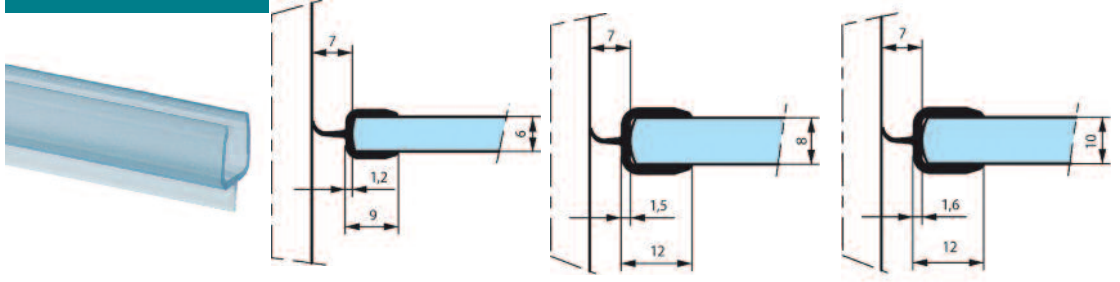

Références / References



Joint translucide à lèvre centrale  
*Translucent sealing strip with central lip*

1801.66.2

1801.66.3

1801.66.4

- Longueur 2200 mm
- Unité de vente : 1 joint, conditionné par 5

- Length 2200 mm
- Sold in units, packed by 5

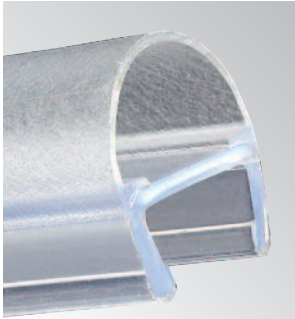

LES + PRODUITS

*The + product*

Améliore  
l'étanchéité

Gamme complète

*Improved  
waterproofing*

*Complete range*

1806.66.\*

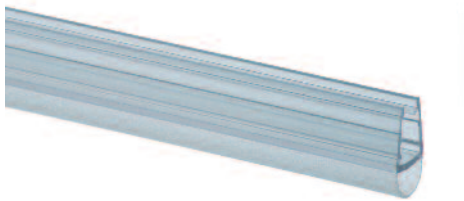

1806.66.0

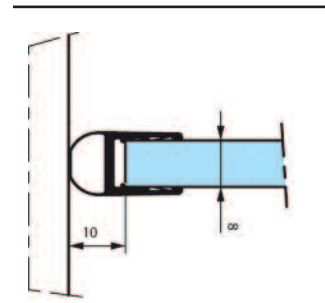
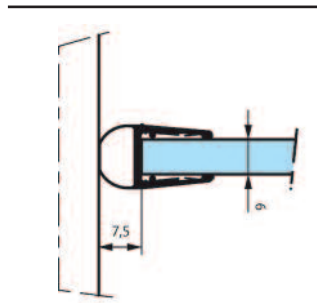

1806.66.4

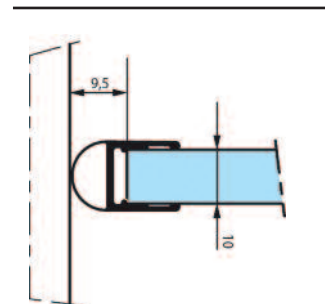
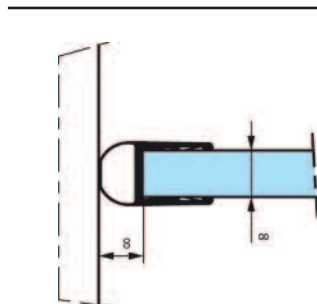

Références / References



Joint translucide bourrelet  
*Translucent sealing strip with compressor*

1806.66.0

1806.66.4

- Longueur 2200 mm
- Unité de vente : 1 joint, conditionné par 5

- Length 2200 mm
- Sold in units, packed by 5

1800.66.\*

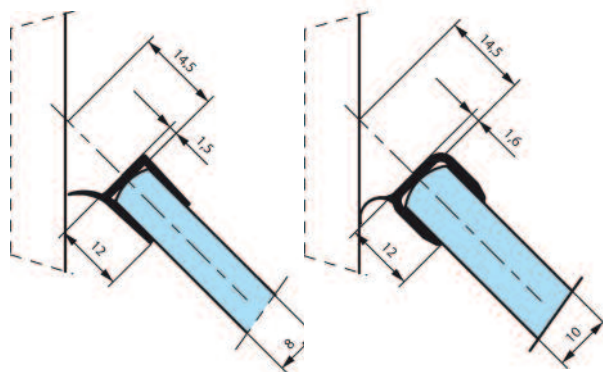

Jointes pour portes  
et pare douches  
Sealing strips for  
shower doors and  
screens

Références / References

Joint translucide à lèvres déportée  
Translucent sealing strip with off-set lip

- Longueur 2200 mm
- Unité de vente : 1 joint, conditionné par 1



1800.66.3



1800.66.4

- Length 2200 mm
- Sold in units, packed by 1

1806.66.\* MR

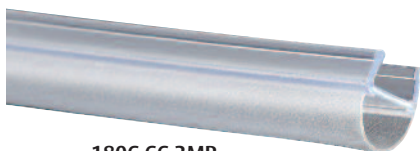

1806.66.3MR



1806.66.4MR

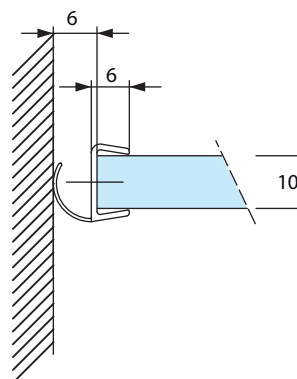
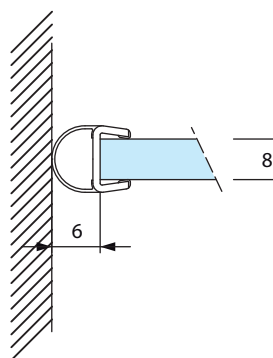

Références / References

Joint translucide bourrelet masse réduite  
Translucent super slim seal with lip compressor

- Longueur 2200 mm
- Unité de vente : 1 joint, conditionné par 1



1806.66.3MR



1806.66.4MR

- Length 2200 mm
- Sold in units, packed by 1

Jointes pour portes  
et pare douches  
*Sealing strips for  
shower doors and  
screens*

## 1802.66.\*

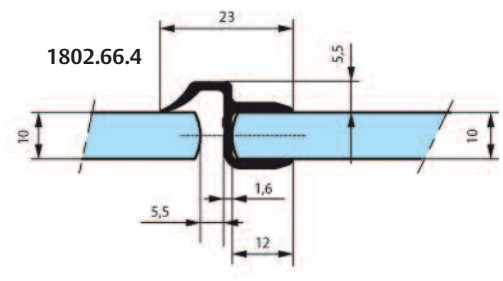
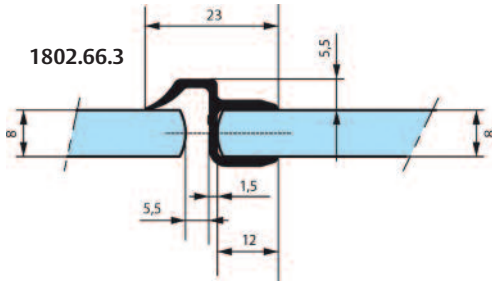
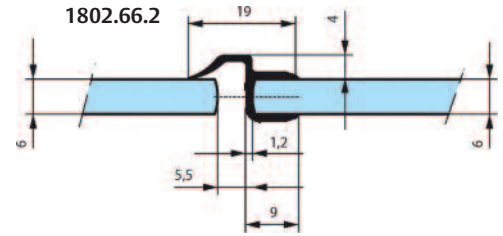

### Références / References

Joint translucide à lèvre déportée  
*Translucent sealing strip with off-set lip*



1802.66.2

1802.66.3

1802.66.4

- Préconisé pour une utilisation entre un volume fixe et un volume mobile à 180°
- Longueur 2200 mm
- Unité de vente : 1 joint, conditionné par 5

- Recommended to prevent water escaping between a fixed and moving panel at 180°
- Length 2200 mm
- Sold in units, packed by 5

## 1803.66.\*

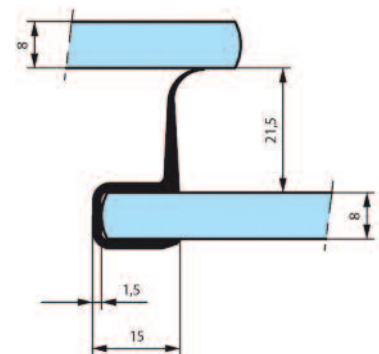
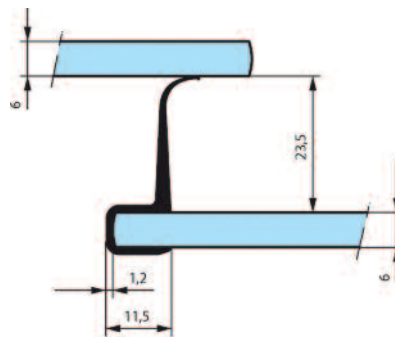
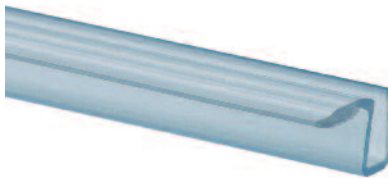

### Références / References

Joint translucide à lèvre latérale  
*Translucent sealing strip with lateral lip*



1803.66.2

1803.66.3

- Pour charnières à recouvrement 3163
- Longueur 2200 mm
- Unité de vente : 1 joint, conditionné par 1

- For overlapping shower hinges 3163
- Length 2200 mm
- Sold in units, packed by 1

## 1808.66.0

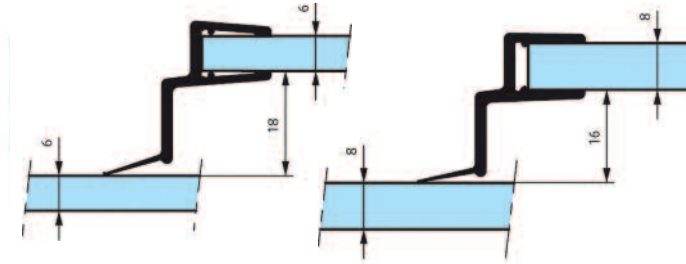
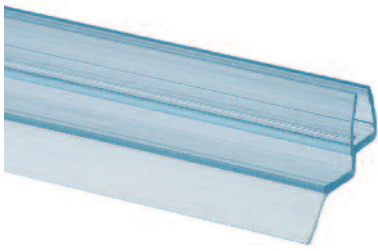

Joints pour portes  
et pare douches  
*Sealing strips for  
shower doors and  
screens*

### Références / References



Joint translucide à lèvres latérales  
*Translucent sealing strip with lateral lip*

1808.66.0

- Pour charnière à recouvrement 3063
- Longueur 2200 mm
- Unité de vente : 1 joint, conditionné par 1

- For overlapping shower hinge 3063
- Length 2200 mm
- Sold in units, packed by 1

## 1803.66.3MR

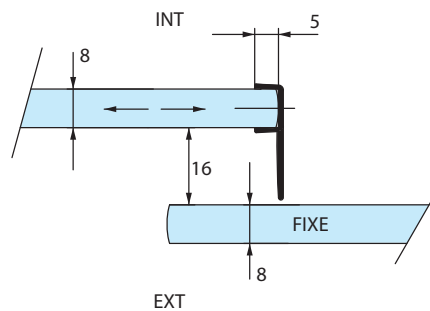

### Références / References



Joint translucide à lèvres latérales masse réduite  
*Translucent super slim seal with lateral lip*

1803.66.3MR

- Longueur 2010 mm
- Unité de vente : 1 joint, conditionné par 1

- Length 2010 mm
- Sold in units, packed by 1

## 1804.66.3

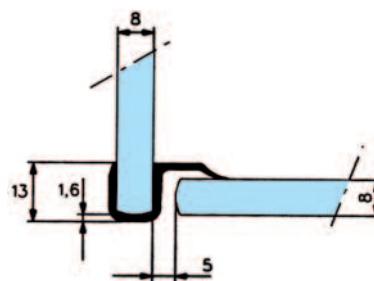
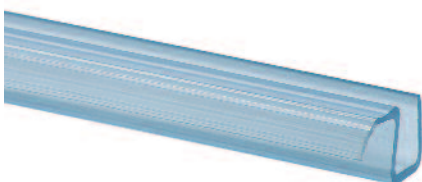

### Références / References



Joint translucide à lèvres avec butée  
*Translucent sealing strip with lip and stop*

1804.66.3

- Préconisé pour une utilisation entre un volume fixe et un volume mobile à 90°
- Longueur 2200 mm
- Unité de vente : 1 joint, conditionné par 1

- Recommended to prevent water escaping between a fixed and moving panel at 90°
- Length 2200 mm
- Sold in units, packed by 1



Joint pour portes  
et pare douches  
*Sealing strips for  
shower doors and  
screens*

1805.66.\*

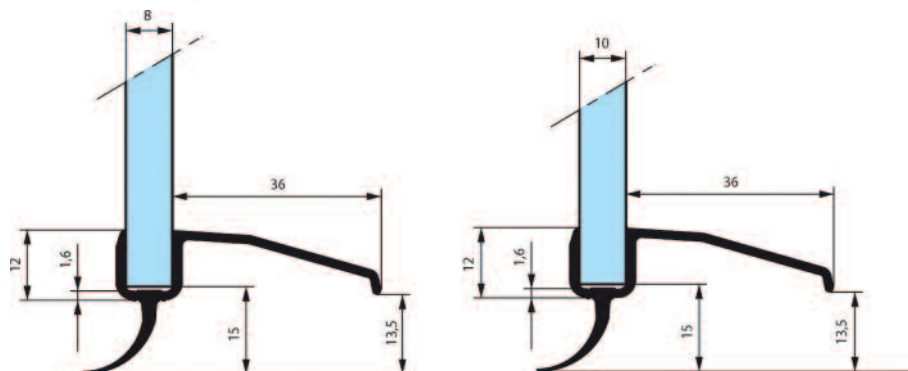
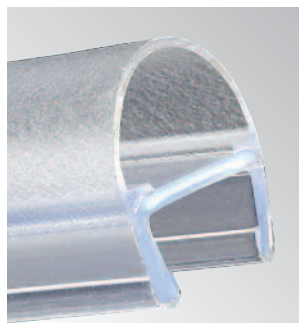

Références / References

Joint translucide bas de porte  
*Translucent sealing strip for bottom of door*

1805.66.3

1805.66.4

- Longueur 2200 mm
- Unité de vente : 1 joint, conditionné par 1

- Length 2200 mm
- Sold in units, packed by 1

1809.66.0

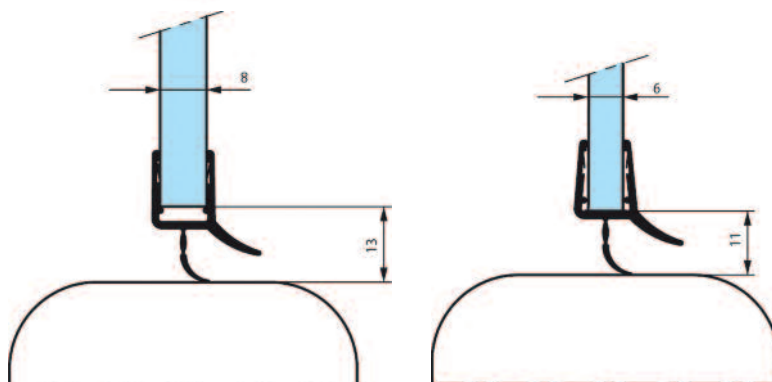

Références / References

Joint translucide bas de porte  
*Translucent sealing strip for bottom of door*

1809.66.0

- Longueur 2000 mm
- Unité de vente : 1 joint, conditionné par 5

- Length 2000 mm
- Sold in units, packed by 5

Jointes pour portes  
et pare douches  
*Sealing strips for  
shower doors and  
screens*



Jointes pour portes  
et pare douches  
*Sealing strips for  
shower doors and  
screens*

2900.66.\*

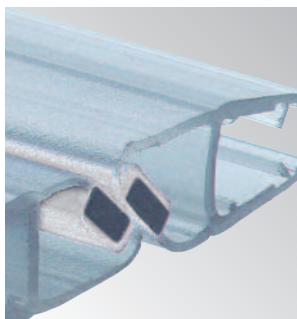

**LES + PRODUITS**

*The + product*

Double fonction :  
blocage et optimisation  
de l'étanchéité

*Double function :  
blocking and  
improved waterproofing*

2900.66.3

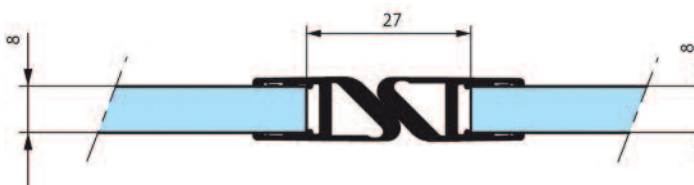
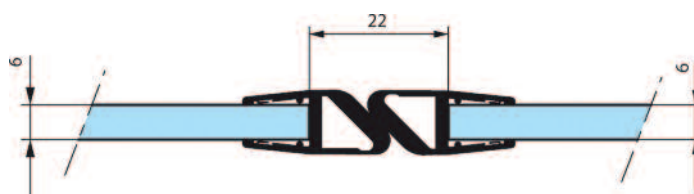

2900.66.4

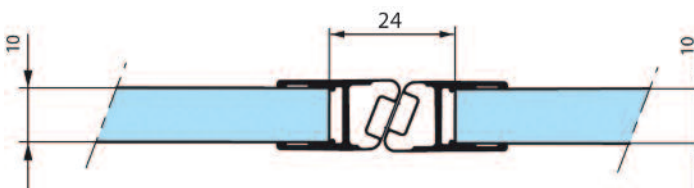
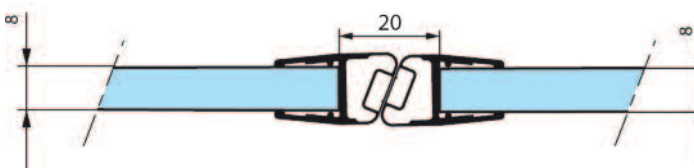

Références / References



Jointes magnétiques translucides  
*Magnetic translucent sealing strip*

2900.66.3

2900.66.4

- Préconisé pour assurer la fermeture entre 2 volumes à 180°
- Longueur 2200 mm
- Unité de vente : 1 joint, conditionné par 1

- Recommended for 2 panels at 180°
- Length 2200 mm
- Sold in units, packed by 1

2901.66.\*



Joints pour portes  
 et pare douches  
*Sealing strips for  
 shower doors and  
 screens*

2901.66.3

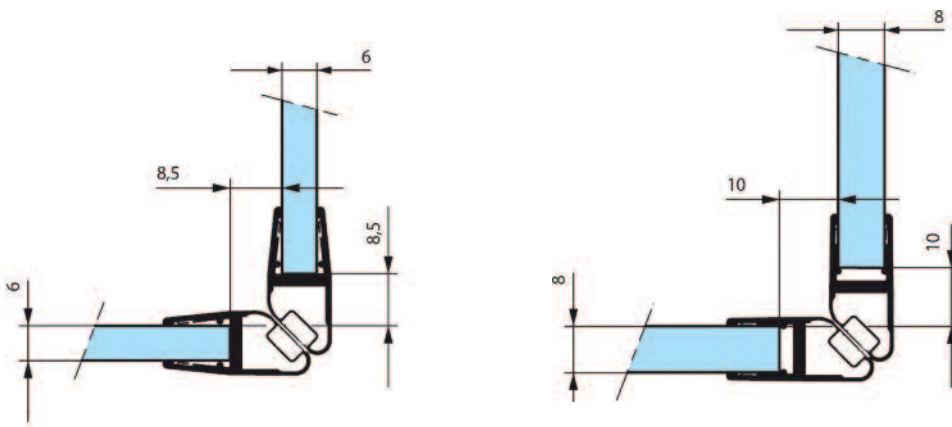

2901.66.4

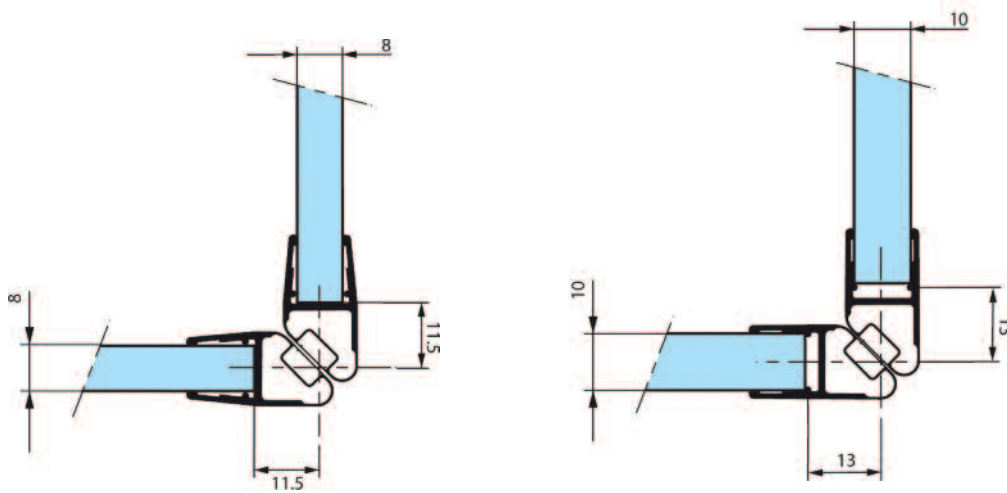

Références / References

Joints magnétiques translucides  
*Magnetic translucent sealing strip*

- Préconisé pour assurer la fermeture entre 2 volumes à 90°
- Longueur 2200 mm
- Unité de vente : 1 joint, conditionné par 1

- Recommended for 2 panels at 90°
- Length 2200 mm
- Sold in units, packed by 1



2901.66.3



2901.66.4

Jointes pour portes  
et pare douches  
*Sealing strips for  
shower doors and  
screens*

## 2902.66.\*

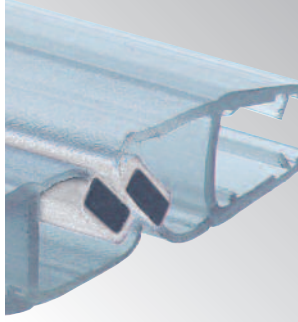

2902.66.3

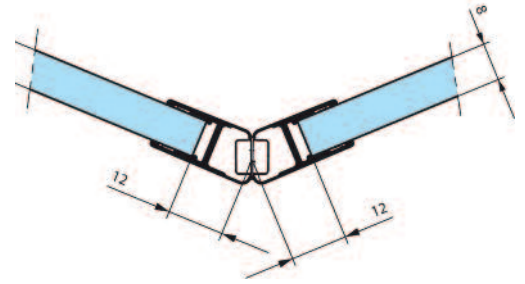
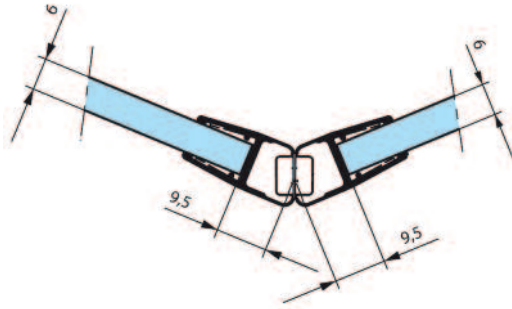

2902.66.4

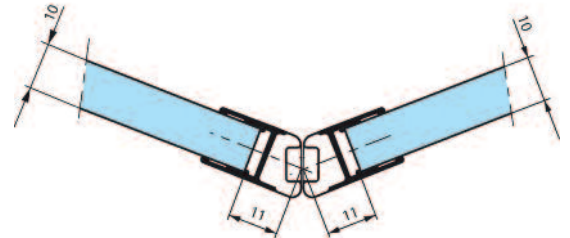
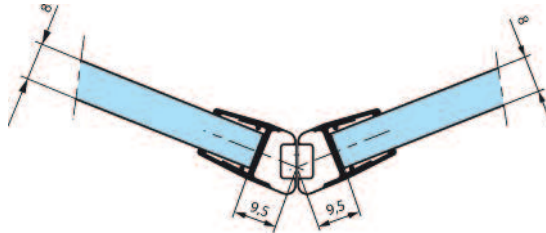

### Références / References

Jointes magnétiques translucides  
*Magnetic translucent sealing strip*



2902.66.3

2902.66.4

- Préconisé pour assurer la fermeture entre 2 volumes à 135°
- Longueur 2200 mm
- Unité de vente : 1 joint, conditionné par 1

- Recommended for 2 panels at 135°
- Length 2200 mm
- Sold in units, packed by 1

## 2903.66.3

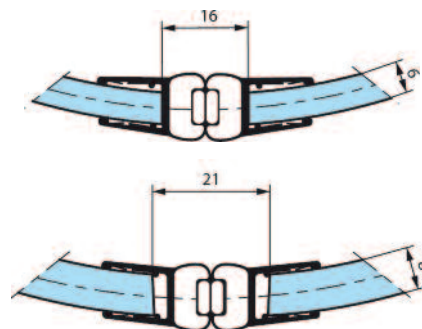

### Références / References

Jointes magnétiques translucides  
*Magnetic translucent sealing strip*



2903.66.3

- Préconisé pour assurer la fermeture entre 2 volumes bombés
- Longueur 2200 mm
- Unité de vente : 1 joint, conditionné par 1

- Recommended for 2 curved glass panels
- Length 2200 mm
- Sold in units, packed by 1