

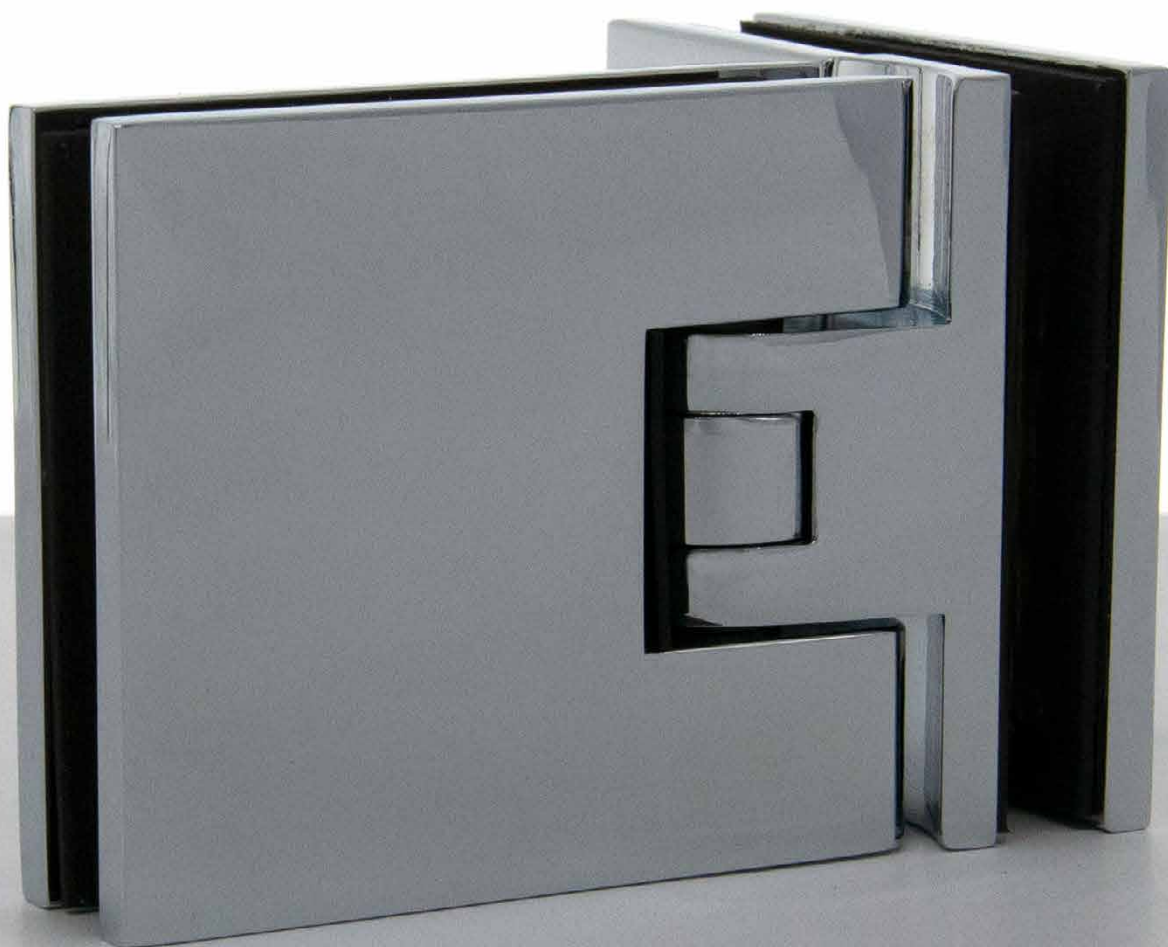

GLASTÜRSYSTEME

GLASS DOOR SYSTEMS

Produktkatalog 04/2021
Product Catalogue 04/2021



WICHTIGE HINWEISE
IMPORTANT INFORMATION

Fertigungstechnische Toleranzen und Änderungen sind uns vorbehalten. Alle Angaben ohne Gewähr.

We explicitly reserve the right of production tolerances and changes in our products.

MIT TRADITION, HANDWERK & LEIDENSCHAFT

Unsere Beschläge fertigen wir in der Regel aus hochwertigem und solidem Messing, in Sonderheit die für den Sanitärbereich. Messing ist ein sehr langlebiges und vielseitiges Material, mit einigen entscheidenden Vorteilen:

- **Sicherheit.** Messing ist nicht nur stabil, sondern hat gleichzeitig eine gewisse Flexibilität. Schon die alten Seefahrer wussten nicht nur die Druck, sondern auch die Schlagfestigkeit zu schätzen: große Vorteile gegenüber spröderen Metallen.
- **Oberflächen.** Neben den sehr guten Werten bei der Korrosions beständigkeit lässt sich Messing hervorragend polieren und besonders mit galvanischen Oberflächen veredeln, z.B. mit Chrom. Messing wird dementsprechend vielfältig in der Sanitärindustrie als Basismaterial für Armaturen genutzt.
- **Sonderlösungen.** Messing lässt sich mit der richtigen Manufaktur einrichtung gut zerspanen und bearbeiten und bietet gleichzeitig beste Voraussetzungen für verschiedenste Oberflächen.

Nicht nur bei der Auswahl der Materialien setzen wir auf Hochwertigkeit. Bis heute steht Handarbeit als Garant für gute Qualität – und das zu Recht. Unsere Produkte werden fast ausschließlich in unserer Manufaktur in Waldbröl händisch gefertigt. Materialauswahl und Fertigung vor Ort dienen auch der Nachhaltigkeit, ein wesentliches Ziel unseres Unternehmens.

Unser Team, bestehend u.a. aus Ingenieuren, Meistern und Glastechnikern, arbeitet stets daran, unsere Produkte in Funktionalität und Design zu perfektionieren. Auch bei der Fertigung von Sonderlösungen oder der Planung komplexer Projekte sind wir gerne Ihr Ansprechpartner und unterstützen Sie bei Ihrem Bauvorhaben.

WITH TRADITION, PASSION & CRAFTSMANSHIP

We usually manufacture our fittings from high-quality and solid brass, at least those for use in the sanitary area.

Brass is a very durable and versatile material, with some key advantages:

- **Security.** Brass is not only stable, but also has a certain flexibility. Even the old time sailors appreciated not only the pressure- but also the impact resistance: great advantages over more rough metals.
- **Finishes.** In addition to the very good attributes for corrosion resistance, brass can be polished excellently and especially refined with plating finishes, e.g. with chrome. Accordingly, brass is widely used in the sanitary industry as a base material for fittings.
- **Custom Manufacturing.** Brass can be easily machined and processed with the right manufacturing equipment and at the same time offers the best conditions for a wide variety of finishes.

We do not only focus on high quality when selecting the materials. To this day, manual work is a guarantee of good quality – and rightly so. Our products are almost exclusively made by hand in our factory in Waldbroel, Germany. Material selection and on-site production also serve sustainability, a key goal of our company.

Our team, consisting of engineers, masters and glass technicians, is always working to perfect our products in terms of functionality and design. We are also happy to be your contact for the production of special solutions or the planning of complex projects and support you with our expertise.



5 JAHRE GARANTIE

5 YEAR WARRANTY

MADE IN GERMANY



5 JAHRE HERSTELLERGARANTIE AUF FOLGENDE PRODUKTE:

5 YEAR MANUFACTURER WARRANTY FOR THE FOLLOWING PRODUCTS:

Wellness, Wellness Premium, Wellness HS, Wellness HS CL, Fit, Next HS, Next HS CL, Milano Original Premium, Milano Original, Milano, Milano Pur, Chalet AT, Chalet PT, Stratego, Filigrano, Türgriffe Door Handles

DUSCHTÜR BESCHLÄGE

SHOWER DOOR HINGES









ANSCHLAGTÜRSYSTEME

SINGLE ACTION DOOR SYSTEMS

	Wellness	02
	Wellness Premium	03
	Wellness HS	04
	Wellness HS CL	05
	CLASSTEC® Bella	07

PENDELTÜRSYSTEME

DOUBLE ACTION DOOR SYSTEMS

	Fit	09
	Milano	13
	Milano Pur	15
	Milano Original	11
	Milano Original Premium	12
	Next HS	10
	Next HS CL	11
	CLASSTEC® Vital	16

CLASSTEC®

2 JAHRE GARANTIE

2 YEAR WARRANTY



2 JAHRE HERSTELLERGARANTIE AUF FOLGENDE PRODUKTE:
2 YEAR MANUFACTURER WARRANTY FOR THE FOLLOWING PRODUCTS:

CLASSTEC® Bella, CLASSTEC® Vital

ZUBEHÖR

ACCESSORIES



Stabilisationsstangen &
Handtuchhalter
Support & Towel Bars

29



Türgriffe
Door Handles

36

GLASTÜRBESCHLÄGE

GLASS DOOR HINGES

ANSCHLAGTÜRSYSTEM

SINGLE ACTION DOOR SYSTEM



Chalet AT

40

PENDELTÜRSYSTEM

DOUBLE ACTION DOOR SYSTEM



Chalet PT

42

OBERFLÄCHEN, GRAVUR & VEREDELUNGEN









48

FINISHES & ENGRAVING

ÜBERSICHT

OVERVIEW







- Entspricht der Spezifikation
Corresponds to the specifications
- Oder nach innen öffnend
Or inwards opening

								
	Wellness	Wellness Premium	Wellness HS	Wellness HS CL	CLASSTEC® Bella	Fit	Milano	Milano Pur
Anschlagtürsystem Opening outwards	■	■	■	●	●			
Pendeltürsystem Opening inwards and outwards						●	●	●
Hebe-Senk Mechanismus Gravity based lifting mechanism			●	●				
Flächenbündige Verschraubung Countersunk screws				●				
Für Rundduschen geeignet Suitable for round shower enclosures	●	●	●					
Ideal für Faltlösungen Ideal for folding solutions	●	●	●	●	●			
Badewannenaufsätze Bathtub glass screen	●	●	●	●	●			
Saunavarianten erhältlich Sauna type hinges available						●		
Für Duschtürsysteme konzipiert Designed for Shower Door Systems	●	●	●	●	●	●	●	●
Nulllage stufenlos einstellbar Adjustable index position		●	●	●		●	●	●
Durchgehende Dichtung (By-Pass-System) Continuous seal (By-Pass-System)	●	●	●	●	●			
Selbstschließend, Softclose Self-closing, Softclose								
Vollabgedeckte Verschraubung Covered backplate, no visible screws			●		●			
Wandanschraubplatte mit Langloch Wallbracket with slotted hole		●	●	●	●	●	●	●
In das Band integrierte Dichtung Integrated seal in hinge						●		
Standard Glasstärke(n) in mm Standard glass thickness(es) in mm	8	8	8	8	8	8	8 & 10	8 & 10
Max. Türgröße in mm Max door size in mm	1000 x 2250	1000 x 2250	900 x 2250	900 x 2250	1000 x 2250	1000 x 2250	1000 x 2250	1000 x 2250
Max. Türgewicht Max door weight	40 kg	40 kg	35 kg	35 kg	40 kg	40 kg	40 kg	40 kg

ÜBERSICHT

OVERVIEW

- Entspricht der Spezifikation
Corresponds to the specifications
- Oder nach innen öffnend
Or inwards opening

	 Milano Original	 Milano Original Premium	 Next HS	 Next HS CL	 CLASSTEC® Vital	 Chalet AT	 Chalet PT
Anschlagtürsystem Opening outwards						●	
Pendeltürsystem Opening inwards and outwards	●	●	●	●	●		●
Hebe-Senk Mechanismus Gravity based lifting mechanism			● +/- 5 mm	● +/- 5 mm			
Flächenbündige Verschraubung Countersunk screws				●			
Für Rundduschen geeignet Suitable for round shower enclosures							
Ideal für Faltlösungen Ideal for folding solutions							
Badewannenaufsätze Bath tub glass screen							
Saunavarianten erhältlich Sauna type hinges available	●					●	
Für Duschtürsysteme konzipiert Designed for Shower Door Systems	●	●	●	●	●	○ optional	
Nulllage stufenlos einstellbar Adjustable index position	●	● 3-Punkt 3-Point	●	●	●		● +/- 2,5°
Durchgehende Dichtung (By-Pass-System) Continuous seal (By-Pass-System)							
Selbstschließend, Softclose Self-closing, Softclose						●	●
Vollabgedeckte Verschraubung Covered backplate, no visible screws	●	●	●			●	
Wandanschraubplatte mit Langloch Wallbracket with slotted hole		●	●	●			
In das Band integrierte Dichtung Integrated seal in hinge			●	●			
Standard Glasstärke(n) in mm Standard glass thickness(es) in mm	8 & 10	8 & 10	8 & 10	8 & 10	8	8	10
Max. Türgröße in mm Max door size in mm	1000 x 2250	1000 x 2250	900 x 2250	900 x 2250	1000 x 2000	1000 x 2100	1000 x 2500
Max. Türgewicht Max door weight	50 kg	50 kg	40 kg	40 kg	40 kg	45 kg	65 kg

WELLNESS



EIGENSCHAFTEN
FEATURES

MAX. TÜRMASSE
MAX. DOOR DIMENSIONS
1.000 x 2.250 mm

GLAS (ESG)
GLASS (TSG)
8 mm

TÜRGEWICHT
DOOR WEIGHT
40 kg

OBERFLÄCHEN
FINISHES



Sonderoberflächen möglich
other finishes on request

ANSCHLAGTÜRSYSTEM
SINGLE ACTION DOOR SYSTEM

FUNKTIONEN
FEATURES

Nach innen oder außen öffnend
Durchgehende Dichtung (By-Pass-System)
Für Rundduschen und Falttüren geeignet

Opening in- or outwards
Continuous seal (By-Pass-System)
Suitable for round showers and folding doors

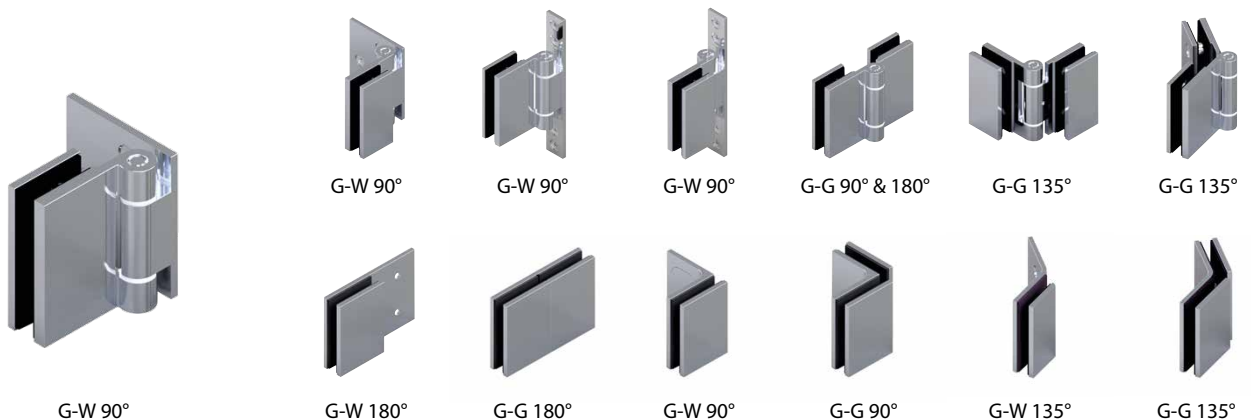

ANSCHLAGTÜRSYSTEM
SINGLE ACTION DOOR SYSTEM



WELLNESS PREMIUM



EIGENSCHAFTEN
FEATURES

MAX. TÜRMASSE
MAX. DOOR DIMENSIONS
1.000 x 2.250 mm

GLAS (ESG)
GLASS (TSG)
8 mm

TÜRGEWICHT
DOOR WEIGHT
40 kg

OBERFLÄCHEN
FINISHES



Sonderoberflächen möglich
other finishes on request

ANSCHLAGTÜRSYSTEM
SINGLE ACTION DOOR SYSTEM

FUNKTIONEN
FEATURES

Einstellbare Nulllage
Adjustable index position
Durchgehende Dichtung (By-Pass-System)
Continuous seal (By-Pass-System)
Wahlweise nach innen oder außen öffnend
Opens inwards or outwards
Für Rundduschen und Falldüren geeignet
Suitable for round showers and folding doors

Adjustable index position
Continuous seal (By-Pass-System)
Opens inwards or outwards
Suitable for round showers and folding doors



ANSCHLAGTÜRSYSTEM
SINGLE ACTION DOOR SYSTEM



WELLNESS HS

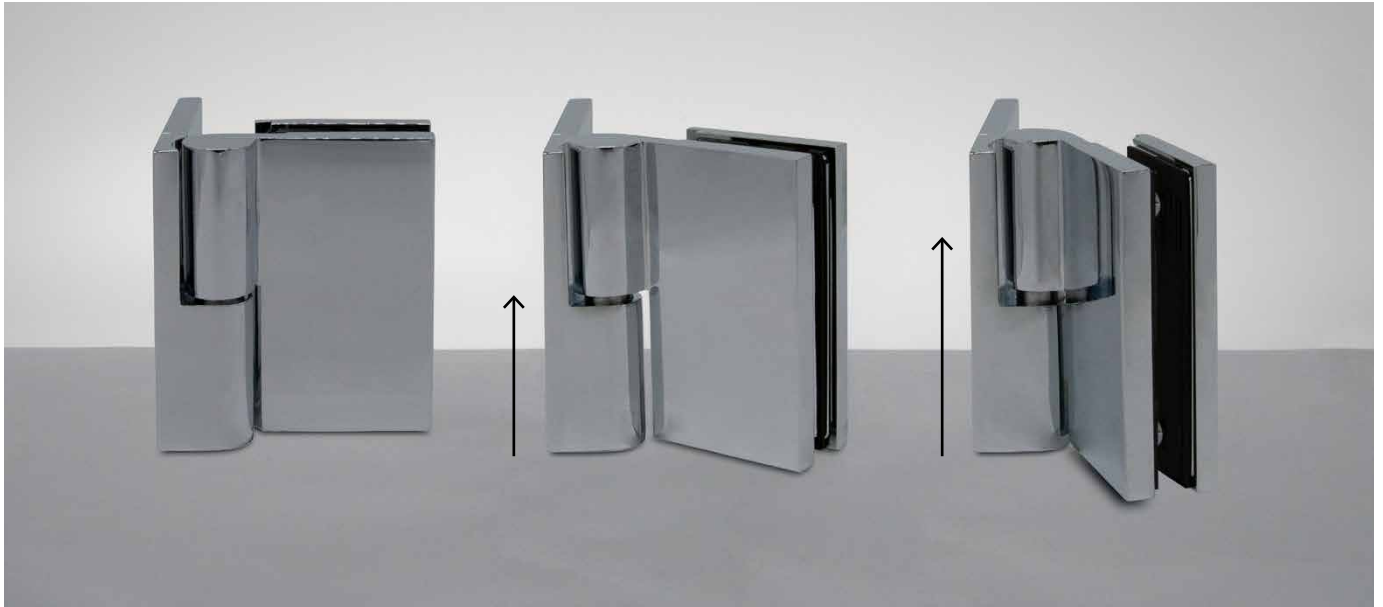

EIGENSCHAFTEN
FEATURES

MAX. TÜRMÄÙE
MAX. DOOR DIMENSIONS
900 x 2.250 mm

GLAS (ESG)
GLASS (TSG)
8 mm

TÜRGEWICHT
DOOR WEIGHT
35 kg

OBERFLÄCHEN
FINISHES



Sonderoberflächen möglich
other finishes on request

ANSCHLAGTÜRSYSTEM
SINGLE ACTION DOOR SYSTEM

FUNKTIONEN
FEATURES

Einstellbare Nulllage
Durchgehende Dichtung (By-Pass-System)
Hebe-Senk Mechanismus
Vollabgedeckte Verschraubung

Adjustable index position
Continuous seal (By-Pass-System)
Gravity based lifting hinge
Covered backplate, no visible screws





WELLNESS HS CL



EIGENSCHAFTEN
FEATURES

MAX. TÜRMASSE
MAX. DOOR DIMENSIONS
900 x 2.250 mm

GLAS (ESG)
GLASS (TSG)
8 mm

TÜRGEWICHT
DOOR WEIGHT
35 kg

OBERFLÄCHEN
FINISHES



Sonderoberflächen möglich
other finishes on request

ANSCHLAGTÜRSYSTEM
SINGLE ACTION DOOR SYSTEM

FUNKTIONEN
FEATURES

Einstellbare Nulllage
Flächenbündige Verschraubung
Durchgehende Dichtung (By-Pass-System)
Hebe-Senk Mechanismus

Adjustable index position
Countersunk screws
Continuous seal (By-Pass-System)
Gravity based lifting hinge





CLASSTEC® Bella



EIGENSCHAFTEN
FEATURES

MAX. TÜRMASSE
MAX. DOOR DIMENSIONS
1.000 x 2.250 mm

GLAS (ESG)
GLASS (TSG)
8 mm

TÜRGEWICHT
DOOR WEIGHT
40 kg

OBERFLÄCHEN
FINISHES



Sonderoberflächen möglich
other finishes on request

ANSCHLAGTÜRSYSTEM
SINGLE ACTION DOOR SYSTEM

FUNKTIONEN
FEATURES

Vollabgedeckte Verschraubung

Covered backplate



G-W 90°



G-W 90°



G-W 90°



G-G 90° & 180°



G-W 90°



G-G 90°



FIT



EIGENSCHAFTEN
FEATURES

MAX. TÜRMASSE
MAX. DOOR DIMENSIONS
1.000 x 2.250 mm

GLAS (ESG)
GLASS (TSG)
8 mm

TÜRGEWICHT
DOOR WEIGHT
40 kg

OBERFLÄCHEN
FINISHES



Sonderoberflächen möglich
other finishes on request

PENDELTÜRSYSTEM
DOUBLE ACTION DOOR SYSTEM

FUNKTIONEN
FEATURES

Einstellbare Nulllage
In das Band integrierte Dichtung
Als Saunavariante erhältlich

Adjustable index position
Integrated seal in hinge
Sauna type hinge available

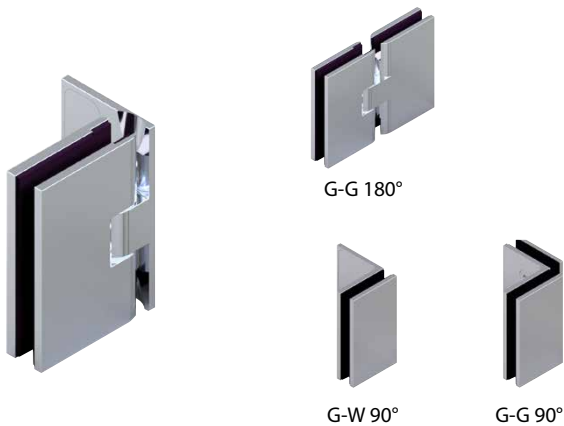



MILANO



EIGENSCHAFTEN
FEATURES

MAX. TÜRMASSE
MAX. DOOR DIMENSIONS
1.000 x 2.250 mm

GLAS (ESG)
GLASS (TSG)
8 & 10 mm

TÜRGEWICHT
DOOR WEIGHT
40 kg

OBERFLÄCHEN
FINISHES

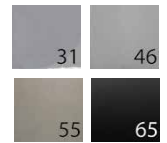

Sonderoberflächen möglich
other finishes on request

PENDELTÜRSYSTEM
DOUBLE ACTION DOOR SYSTEM

FUNKTIONEN
FEATURES

Einstellbare Nulllage

Adjustable index posi

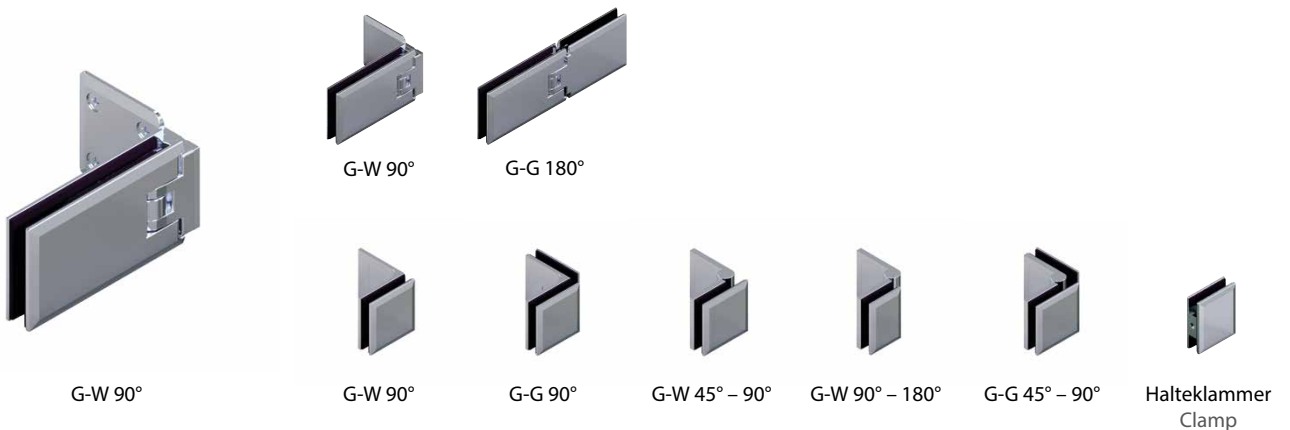

PENDELTÜRSYSTEM
DOUBLE ACTION DOOR SYSTEM



MILANO PUR



EIGENSCHAFTEN
FEATURES

MAX. TÜRMASSE
MAX. DOOR DIMENSIONS
1.000 x 2.250 mm

GLAS (ESG)
GLASS (TSG)
8 & 10 mm

TÜRGEWICHT
DOOR WEIGHT
40 kg

OBERFLÄCHEN
FINISHES

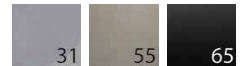

Sonderoberflächen möglich
other finishes on request

PENDELTÜRSYSTEM
DOUBLE ACTION DOOR SYSTEM

FUNKTIONEN
FEATURES

Einstellbare Nulllage

Adjustable index position

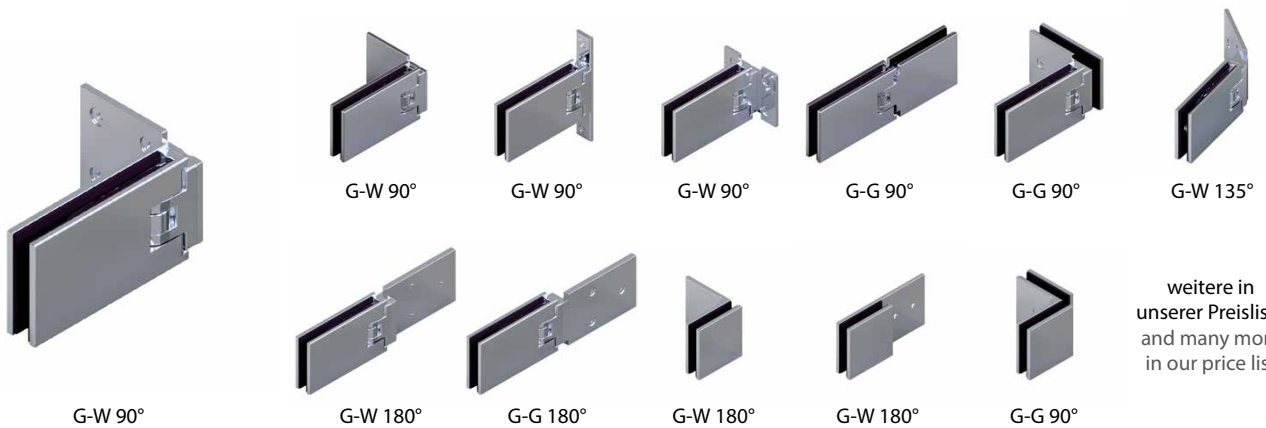

weitere in
unserer Preisliste
and many more
in our price list



MILANO ORIGINAL



EIGENSCHAFTEN
FEATURES

MAX. TÜRMAßE
MAX. DOOR DIMENSIONS
1.000 x 2.250 mm

GLAS (ESG)
GLASS (TSG)
8 & 10 mm

TÜRGEWICHT
DOOR WEIGHT
50 kg

OBERFLÄCHEN
FINISHES

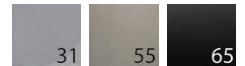

Sonderoberflächen möglich
other finishes on request

PENDELTÜRSYSTEM
DOUBLE ACTION DOOR SYSTEM

FUNKTIONEN
FEATURES

Einstellbare Nulllage
Vollabgedeckte Verschraubung
Als Saunavariante erhältlich

Adjustable index position
Covered backplate
Sauna type hinge available

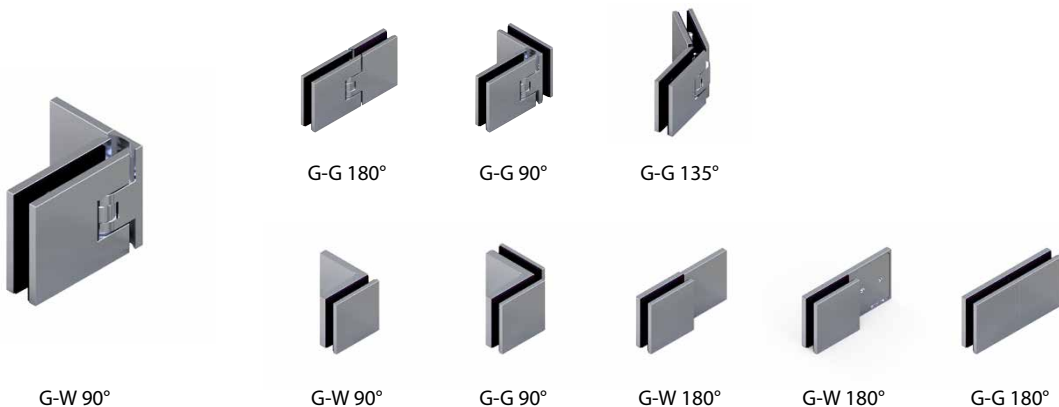



MILANO ORIGINAL PREMIUM



EIGENSCHAFTEN
FEATURES

MAX. TÜRMASSE
MAX. DOOR DIMENSIONS
1.000 x 2.250 mm

GLAS (ESG)
GLASS (TSG)
8 & 10 mm

TÜRGEWICHT
DOOR WEIGHT
50 kg

OBERFLÄCHEN
FINISHES



Sonderoberflächen möglich
other finishes on request

PENDELTÜRSYSTEM
DOUBLE ACTION DOOR SYSTEM

FUNKTIONEN
FEATURES

Einstellbare Nulllage
3-Punkt-Nulllage
Vollabgedeckte Verschraubung

Adjustable index position
3-Point index position
Covered screws

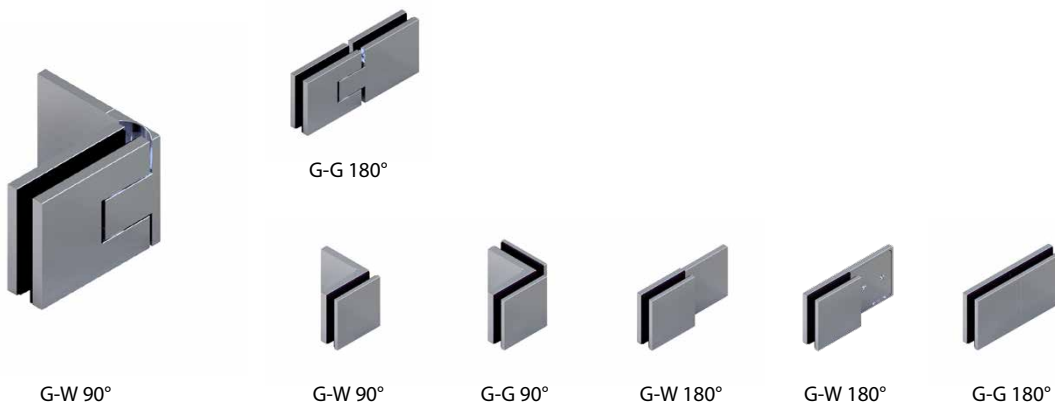

G-W 90°

G-G 180°

G-W 90°

G-G 90°

G-W 180°

G-W 180°

G-G 180°



NEXT HS



EIGENSCHAFTEN
FEATURES

MAX. TÜRMASSE
MAX. DOOR DIMENSIONS
900 x 2.250 mm

GLAS (ESG)
GLASS (TSG)
8 & 10 mm

TÜRGEWICHT
DOOR WEIGHT
40 kg

OBERFLÄCHEN
FINISHES



Sonderoberflächen möglich
other finishes on request

PENDELTÜRSYSTEM
DOUBLE ACTION DOOR SYSTEM

FUNKTIONEN
FEATURES

Einstellbare Nulllage
Ca. 5 mm Hebe-Senk Mechanismus
In das Band integrierte Dichtung
Vollabgedeckte Verschraubung

Adjustable index position
Approx. 5 mm gravity based lifting hinge
Integrated seal in hinge
Covered backplate



G-W 90°



G-G 180°



G-W 90°



G-G 90°

weitere in
unserer Preisliste
and many more
in our price list

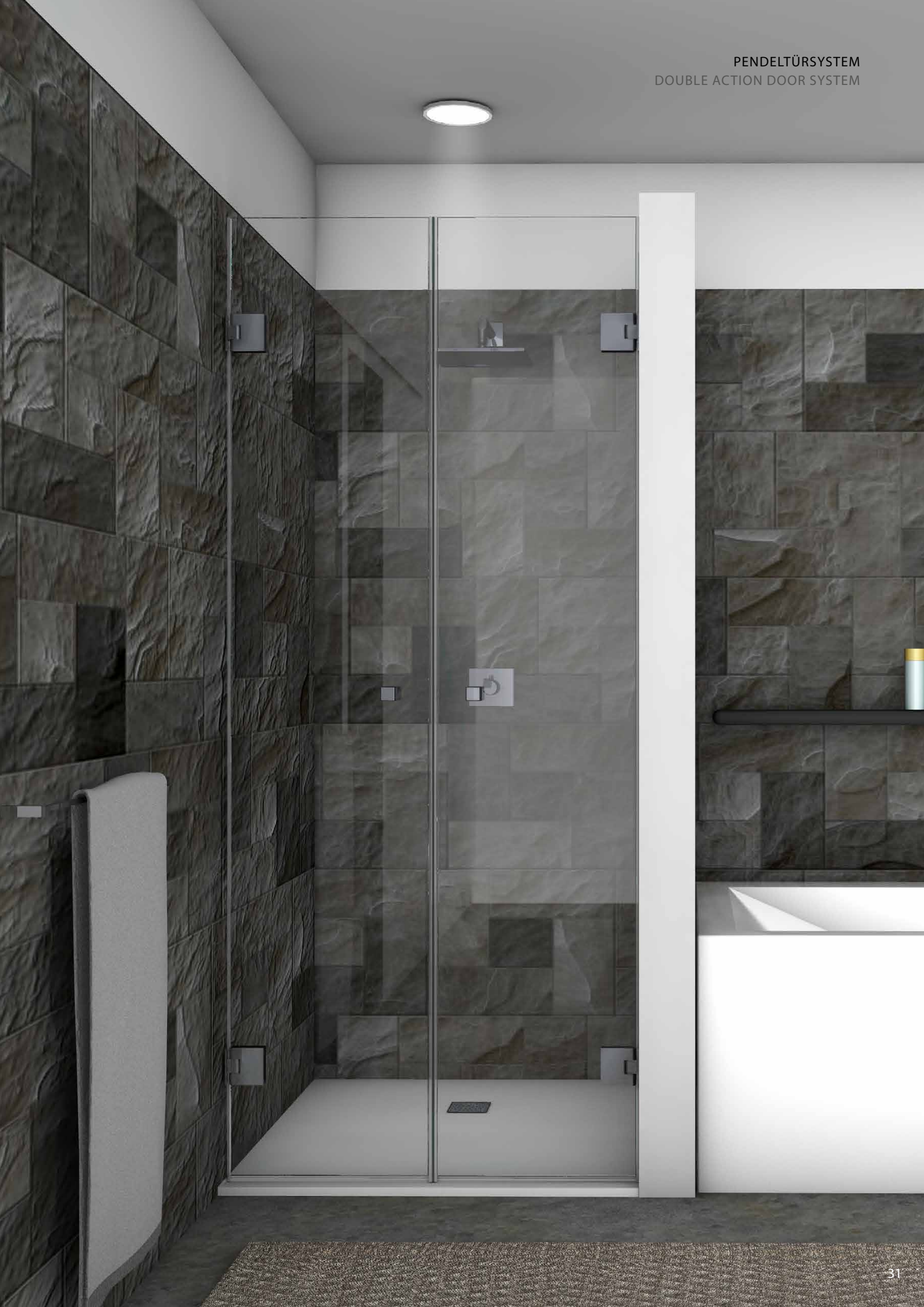

NEXT HS CL



EIGENSCHAFTEN
FEATURES

MAX. TÜRMASSE
MAX. DOOR DIMENSIONS
900 x 2.250 mm

GLAS (ESG)
GLASS (TSG)
8 & 10 mm

TÜRGEWICHT
DOOR WEIGHT
40 kg

OBERFLÄCHEN
FINISHES



Sonderoberflächen möglich
other finishes on request

PENDELTÜRSYSTEM
DOUBLE ACTION DOOR SYSTEM

FUNKTIONEN
FEATURES

Einstellbare Nulllage
Flächenbündige Verschraubung
Ca. 5 mm Hebe-Senk Mechanismus
In das Band integrierte Dichtung
Verbauung ohne Dichtprofile möglich

Adjustable index position
Countersunk screws
Approx. 5 mm gravity based lifting hinge
Integrated seal in hinge
Can be mounted without seals



G-W 90°



G-G 180°



G-W 90°



G-G 90°

weitere in
unserer Preisliste
and many more
in our price list

PENDELTÜRSYSTEM
DOUBLE ACTION DOOR SYSTEM



CLASSTEC® Vital



EIGENSCHAFTEN
FEATURES

MAX. TÜRMASSE
MAX. DOOR DIMENSIONS
1.000 x 2.000 mm

GLAS (ESG)
GLASS (TSG)
8 mm

TÜRGEWICHT
DOOR WEIGHT
40 kg

OBERFLÄCHEN
FINISHES



Sonderoberflächen möglich
other finishes on request

PENDELTÜRSYSTEM
DOUBLE ACTION DOOR SYSTEM

FUNKTIONEN
FEATURES

Stufenlos einstellbare Nulllage

Adjustable index position



G-W 90°



G-G 180°



G-W 90°



G-G 90°





KL MEGLA ZUBEHÖR

ACCESSORIES

Qualität und Sicherheit sind Prämissen, die sich durch unser komplettes Produktportfolio ziehen. Denn auch vermeintliche Kleinigkeiten können über die Stabilität und Haltbarkeit einer Glastüranlage entscheiden. Wir fertigen wir unser Zubehör passend zu unseren Beschlägen an und setzen auch bei unseren Stabilisationsstangen und Griffen auf hochwertiges Messing und Edelstahl.

Bei unseren Dichtprofilen haben Sie die Wahl zwischen Klebe-, Aufsteck- und Magnetdichtprofilen.

Ensuring quality and safety is a major point in our product through our complete product portfolio. Because even little things can influence the stability and durability of a glass door system. We manufacture our accessories to match our fittings and also use high-quality brass and stainless steel for our stabilizing bars and handles.

With our sealing profiles you have the choice between adhesive, plug-on and magnetic sealing profiles.

HANDTUCHHALTER

TOWEL BARS

Basismaterial: hochwertiges Messing base material: high quality brass



Art. No. 06706 – Stratego
G-G, Rohrlänge 1000 mm, 8 mm ESG
g-g, bar length 1000 mm, 8 mm tempered glass



Art. No. 06709 – Stratego
G-G, Rohrlänge 1000 mm mit Griff, 8 mm ESG
g-g, bar length 1000 mm, with door handle, 8 mm tempered glass



Art. No. 06710 – Stratego
Flächenbündige Verschraubung, Rohrlänge 1000 mm, 8 mm ESG
Flush screw, bar length 1000 mm, 8 mm tempered glass



Art. No. 06730 – Filigrano eckig square
G-G, Stablänge 1000 mm, 8 mm ESG
g-g bar length 1000 mm, 8 mm tempered glass



Vierkantstab aus hochwertigem
Edelstahl matt gebürstet (OF 91)
Square bar is made of brushed
stainless steel (finish 91)



Art. No. 06731 – Filigrano eckig square
G-G, Stablänge 1000 mm, mit Griff, 8 mm ESG
g-g bar length 1000 mm, with handle, 8 mm tempered glass



Vierkantstab aus hochwertigem
Edelstahl matt gebürstet (OF 91)
Square bar is made of brushed
stainless steel (finish 91)



Art. No. 06740 – Filigrano rund round
G-G, Stablänge 1000 mm, 8 mm ESG
g-g, bar length 1000 mm, 8 mm tempered glass



Art. No. 06741 – Filigrano rund round
G-G, Stablänge 1000 mm, mit Griff, 8 mm ESG
g-g, bar length 1000 mm, with door handle, 8 mm tempered glass



STRATEGO

STABILISATIONSSTANGEN SUPPORT BARS

Basismaterial: hochwertiges Messing base material: high quality brass



Art. No. 67070

Deckenmontage G-D, Rohrlänge max. 500 mm, 8 mm ESG
Ceiling installation g-c, bar length max. 500 mm, 8 mm tempered glass



Art. No. 67078

G-W 45° Rohrlänge 1000 mm, rechte & linke Scheibe, 8 mm ESG
g-w 45°, bar length 1000 mm, right & left panel, 8 mm tempered glass

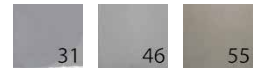

Art. No. 67080 & 67085

G-W 90°, Rohrlänge 1000 & 1500 mm, 8 mm ESG
g-w 90°, bar length 1000 & 1500 mm, 8 mm tempered glass



Art. No. 67087 & 67088

G-W 90°, Bohrung im Glas, Rohrlänge 1000 & 1500 mm, 8 mm ESG
g-w 90°, drill hole in glass, bar length 1000 & 1500 mm, 8 mm tempered glass



Art. No. 67090 & 67095

G-G, Rohrlänge 1000 & 1500 mm, 8 mm ESG
g-g, bar length 1000 & 1500 mm, 8 mm tempered glass



Art. No. 67096

T-Stück mit 90° Glasaufnahme, verschiebbar, Rohrlänge 100 mm, 8 mm ESG
t-unit with 90° glass adapter, moveable, bar length 100 mm, 8 mm tempered glass



FILIGRANO

STABILISATIONSSTANGEN SUPPORT BARS

Basismaterial: hochwertiges Messing base material: high quality brass



Art. No. 67160 & 67180

G-W, verstellbar +/- 90°, Stablänge 1050 & 1500 mm, 6 - 8 mm
g-w, adjustable +/- 90°, bar length 1050 & 1500 mm,
6 - 8 mm tempered safety glass



Art. No. 67161 & 67181

G-W, verstellbar +/- 90°, Stablänge, 1050 & 1500 mm, 10 - 12 mm ESG
g-w, adjustable, +/- 90°, bar length 1050 & 1500 mm,
10 - 12 mm tempered safety glass



Art. No. 67162 & 67182

G-G, verstellbar 0 - 360°, Stablänge, 1050 & 1500 mm, 6 - 8 mm ESG
g-g, adjustable 0 - 360°, bar length 1050 & 1500 mm,
6 - 8 mm tempered safety glass



Art. No. 67163 & 67183

G-G, verstellbar 0 - 360°, Stablänge, 1050 & 1500 mm, 10 - 12 mm ESG
g-g, adjustable, 0 - 360°, bar length 1050 & 1500 mm
10 - 12 mm tempered safety glass



Art. No. 67110 & 67112

G-W, Stablänge 1050 & 1500 mm, 8 mm ESG
g-w, bar length 1050 & 1500 mm, 8 mm tempered safety glass



Art. No. 67120 & 67122

G-G, Stablänge 1050 & 1500 mm, 8 mm ESG
g-g, bar length 1050 & 1500 mm, 8 mm tempered safety glass



Art. No. 67130 & 67132

G-W 45°, Stablänge 1050 & 1500 mm, 8 mm ESG
g-w 45°, bar length 1050 & 1500 mm, 8 mm tempered safety glass



Vierkantstab aus hochwertigem
Edelstahl matt gebürstet (OF 91)
Square bar is made of brushed
stainless steel (finish 91)



Vierkantstab aus hochwertigem
Edelstahl matt gebürstet (OF 91)
Square bar is made of brushed
stainless steel (finish 91)

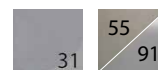

Vierkantstab aus hochwertigem
Edelstahl matt gebürstet (OF 91)
Square bar is made of brushed
stainless steel (finish 91)



Vierkantstab aus hochwertigem
Edelstahl matt gebürstet (OF 91)
Square bar is made of brushed
stainless steel (finish 91)



Weitere Ausführungen und Komponenten finden Sie in unserer Preisliste.
You'll find more variations and components in our price list.



FUNKTIONAL & SCHÖN

FUNCTIONAL & GOOD-LOOKING

Art. No. 05014 & 05015

beidseitig mit Puffer. Ideal für Faltlösungen
double-sided with buffers, ideal for folding doors

TÜRGRIFFE

DOOR HANDLES

Basismaterial: hochwertiges Messing base material: high quality brass



Art. No. 80401
Ø 32 mm, beidseitig, für 8 mm ESG
Ø 32 mm, double-sided, for 8 mm tempered glass



Art. No. 05003 & 05007
Ø 35 mm & ø 32 mm, beidseitig, für 6-12 mm ESG
Ø 35 mm, double-sided, for 6-12 mm tempered glass



Art. No. 05013
Ø 35 mm, beidseitig, Puffer auf der flachen Seite, für 6-12 mm ESG
Ø 35 mm, double-sided, buffer on the flat side, for 6-12 mm tempered glass



Art. No. 05014 & 05015
Ø 35 mm, beidseitig, mit Puffer beidseitig, für 6-12 mm ESG
Ø 35 mm, double-sided, with buffer on both sides, for 6-12 mm tempered glass



Art. No. 05030
30 x 30 x 30 x 30 mm, beidseitig, eckige Form, für 6-12 mm ESG
30 x 30 x 30 x 30 mm, double-sided, square design,
for 6-12 mm tempered glass



Art. No. 05032
30 x 30 x 30 mm, beidseitig, eckige Form, Puffer auf der flachen Seite,
für 6-12 mm ESG
30 x 30 x 30 mm, double-sided, square design, buffer on the flat side,
for 6-12 mm tempered glass

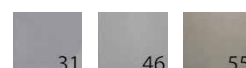

CHALET AT



EIGENSCHAFTEN
FEATURES

MAX. TÜRMASSE
MAX. DOOR DIMENSIONS
1.000 x 2.100 mm

GLAS (ESG)
GLASS (TSG)
8 mm

TÜRGEWICHT
DOOR WEIGHT
45 kg

OBERFLÄCHEN
FINISHES

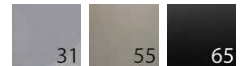

Sonderoberflächen möglich
other finishes on request

ANSCHLAGTÜRSYSTEM
SINGLE ACTION DOOR SYSTEM

FUNKTIONEN
FEATURES

Selbstschließend, Softclose
Einstellbare Schließgeschwindigkeit
Vollabgedeckte Verschraubung
Als Saunavariante erhältlich

Self-closing, Softclose
Adjustable closing speed
Covered backplate, no visible screws
Sauna type hinge available



G-W 90°



G-G 180°

weitere in
unserer Preisliste
and many more
in our price list



CHALET PT



EIGENSCHAFTEN
FEATURES

MAX. TÜRMASSE
MAX. DOOR DIMENSIONS
1.000 x 2.500 mm

GLAS (ESG)
GLASS (TSG)
10 mm

TÜRGEWICHT
DOOR WEIGHT
65 kg

OBERFLÄCHEN
FINISHES

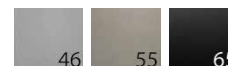

Sonderoberflächen möglich
other finishes on request

PENDELTÜRSYSTEM
DOUBLE ACTION DOOR SYSTEM

BESONDERHEITEN
HIGHLIGHTS

Einstellbare Nulllage (+/- 2,5°)
Selbstschließend

Adjustable index position (+/- 2,5°)
Self-closing



G-W 90°



G-G 180°

weitere in
unserer Preisliste
and many more
in our price list



SONDERANFERTIGUNGEN...

CUSTOMIZED PRODUCTS...



...AUS UNSERER MANUFAKTUR

Anspruchsvolle Kunden, besondere bauliche Gegebenheiten, etc. erfordern ein spezielles Know-How und spezielle Materialien, Form und Farbe. Egal, ob es um das Gravieren eines Logos, Beschläge in Sonderform oder technische Besonderheiten geht – mit uns realisieren Sie Glasprojekte in jeder Größe und Farbe, mit allen Facetten und Möglichkeiten. Senden Sie uns gerne eine Anfrage, wir setzen uns dann schnellstmöglich mit Ihnen in Verbindung.

...FROM OUR MANUFACTURE

Demanding customers and unusual structural conditions are only two factors, which require many years of experience, know-how and special materials when realizing a glazing project. It may be just another shape and color you are looking for, the engraving a logo, or maybe you need a specialized fitting with special technical features - regardless of what you may need for your project, any size and color, with all facets and possibilities. We are here to help - Please send us an inquiry and we will contact you as soon as possible.

STANDARD OBERFLÄCHEN

STANDARD FINISHES

Weitere Oberflächen finden Sie in unserer Preisliste | More finishes can be found in our price list

10	Silberfarbig eloxiert	Silver color anodized
31	Glanzverchromt	Bright chrome
46	Mattverchromt	Satin chrome
55	Nickel gebürstet (Edelstahloptik)	Brushed nickel (stainless steel look)
65	ONYX schwarz	ONYX black
91	Edelstahl gebürstet	Brushed stainless steel



Milano
Glanzverchromt
Bright chrome



Chalet PT
Nickel gebürstet
Brushed nickel



Milano Original
ONYX schwarz
ONYX black

SONDER OBERFLÄCHEN

SPECIAL FINISHES

36	Glanzvernickelt	Bright nickel
51	Mattvernickelt	Satin nickel
59	Messing Braun	Brown brass
61	Feingold	Fine gold
62	Gelbgold (Farbton ähnlich wie Messing)	Yellow gold (brass color)
63	Alt Kupfer gebürstet mit Klarlack	Brushed old copper with clear varnish ^o
64	Altbronze bebürstet mit Klarlack	Brushed old bronze with clear varnish ^o
67	Matt vergoldet	Satin gold plated
68	Vergoldet mit Roségold	Rosé gold plated ^o
69	Messing gebürstet mit Klarlack	Brushed brass with clear varnish ^o
81	RAL 9005 schwarz matt pulverbeschichtet	RAL 9005 matt black powder coated ^{A)}
82	RAL 9010 weiß matt pulverbeschichtet	RAL 9010 white matt powder coated ^{A)}
84	RAL 9005 schwarz glänzend pulverbeschichtet	RAL 9005 glossy black powder coated ^{A)}



Milano
Gelbgold
Yellow gold



Wellness HS
Alt Kupfer gebürstet
Brushed old copper



Chalet PT
Altbronze gebürstet
Brushed old bronze



05003 Griff // Handle
Vergoldet mit Roségold
Rosé gold plated

